

ORGANIZATIONAL GENESIS, IDENTITY AND CONTROL:

THE TRANSFORMATION OF BANKING IN RENAISSANCE FLORENCE

John F. Padgett

Department of Political Science
University of Chicago
&
Santa Fe Institute

jpadgett@midway.uchicago.edu
padgett@santafe.edu

October 1, 1998
Revised: April 25, 2000

Forthcoming, Markets and Networks, edited by Alessandra Casella and James Rauch, New York: Russell Sage, 2000.

This paper was originally prepared for presentation to the seminar series on social and institutional change at the Robert Woods Johnson Foundation, Princeton, N.J., organized by Paul

DiMaggio. I appreciate the insightful comments of Art Stinchcombe on the earlier draft.

**ORGANIZATIONAL GENESIS, IDENTITY AND CONTROL:
THE TRANSFORMATION OF BANKING IN RENAISSANCE FLORENCE**

Organization Theory Background

Current organization theories explain organizational form essentially through selection. That is, instead of focusing on the dynamics of emergence, the field as a whole adopts as its epistemology consequentialism, which emphasizes the relative performances, and hence death rates, of different forms in different environments. The hope of the field is that the performance relationship between form and environment is sufficiently invariant that equilibrium fixed points will be reached, independent of dynamic path.

This shared epistemological stance hardly implies that theoretical consensus has been reached. Strong debates flourish over which selection environment is the most powerful (markets vs. states vs. professions); over what is the proper unit of selection (standard operating procedures vs. contracts vs. legitimation principles vs. structural phenotypes); and over what role strategic choice plays in macro selection (constitutive vs. epiphenomenal). All these debates reveal that "performance", the criterion for selection, is far more difficult to define, much less measure, than may at first

appear. Such operational difficulties aside, the field's epistemological convergence on consequentialism has had the virtue of permitting debates to be tight and well focused.

But this consensus has been purchased at a cost. It is no accident that hardly anyone since Stinchcombe's hoary but path-breaking classic of 1965¹ has broached the topic of the genesis of organizational form, including within that topic, as Stinchcombe did, the systematic relationship between processes of organizational birth and the surrounding social contexts out of which organizations are constructed. This challenging issue² currently is pushed under our collective rug through a variety of simplifying assumptions: biology-inspired organization theories use randomization (sometimes supplemented with diffusion) to sidestep the question; economics-inspired organization theories posit that good ideas are available to everyone (perhaps through costly search); and culture-inspired organization theories rely on ideational templates (themselves

¹Namely, "Social structure and organizations," in Handbook of Organizations, edited by James G. March, Rand McNally 1965.

²This topic is challenging in biology as well. Many authors have pointed out that the impressive advances of the "Modern Synthesis" of Mendel and Darwin into population genetics have been purchased at the cost of "abolishing the organism", that is of ignoring the complex interactive ways in which genotype, coupled with molecular environments through feedback networks of chemical reactions, aggregates up into phenotype, during the process of development. Phenotype is assumed, but not explained, in current natural selection theory. See

not explained). Each of these approaches can deal with reproduction, or choice within given alternatives; none can deal with the genesis of the alternatives themselves.

The lacunae these fixes hide are revealed most obviously in comparative or historical research, which regardless of time or place tends to discover a cornucopia of organizational forms, well beyond the range of our usual Americanist vision. Arguably, all these forms are "adapted" to a local "environment" which has "selected" them on some criteria of "performance". But the sheer diversity of ways in which these analytic terms must be operationalized, to fit various historical cases, threatens to make the entire metaphor vacuous.

The essential theoretical problem, well understood in Stinchcombe's original article, is causal feedback between organizational form(s) and environment(s). In no time or place have organizations faced a fixed topology or landscape of environmental resources over which they must maximize. Not unlike species in the Amazonian jungle, organizations have faced instead a plethora of other interconnected organizations and social networks into which they must fit, the dynamics of which

they themselves affect. Path-dependent histories of co-evolving³ organizational forms can walk and have walked themselves into all sorts of self-sustaining corners of abstract possibility, including many beyond our experience.

Beyond simply waving our hands at the glorious indeterminacy of human (and natural selection) agency, the question of course is how to construct a framework for analyzing systemic interactions and feedback, in such a way as to (post-hoc) explain the emergence of new organizational forms. Here I use my empirical work on Renaissance Florentine banking--arguably the "birthplace" (along with Genoa and a few other Italian city states) of financial capitalism--as a platform both for more closely structuring the analytic problem of organizational genesis and for speculating about empirically plausible theoretical solutions. Perhaps understanding the mechanisms that generated the history-shaping sequence of innovative organizational forms in this one creative epoch will suggest mechanisms underlying organizational genesis more generally.

³Co-evolution, rather than evolution, is the term biologists use to discuss these species interaction effects. Arguably, however, the problem goes deeper than the population dynamics models, based on food webs, typically used to operationalize this concept. See for a premier example May (1973). Such models do not address where species themselves come from, only their relative population sizes.

The Florentine discussion is founded on years of original primary research. Here though I suppress evidentiary detail, to be published elsewhere, using the case simply as springboard to more general thinking about organizational genesis. Let no one mistake the inductive sequence, however: I am inferring general theory from unpacking a particular case. The generality of the conclusions here can only be established through careful comparison with analogous cases.⁴

Structuring the Problem of Organizational Genesis

Viewed from the very proximate perspective of the founder, the birth of an organization can be understood in quasi-biological terms. In both biological and social systems, birth is rooted in a logic of recombination: unlike what our models sometimes imply, spontaneous generation never occurs. It is the absence of a theory of recombination that inhibits social-science understanding of genesis: we need to take more seriously than we do the fact that nothing exists without a history.

The analogue to DNA in social organization is the set of ideas, practices, and social relations of the founder. For

⁴The Santa Fe Institute has created a new research program, entitled “The Co-evolution of States and Markets,” under my direction, which is currently pursuing exactly this agenda. Ongoing participants in this program include Walter Powell, David Stark, and Douglas White.

shorthand, I call this set the 'logic-of-identity' of the founder. At the genotypic level of analysis, it is the recombinatorial history of these ideas, practices and social relations, controlled through social interactions among persons, that social science most needs to understand. To take an example central to this article, who an individual is as a banker is deeply affected by whom that individual is as a person (modified of course by what he has learned in his role). And who the individual is as a person, in turn, is the product of the 'mating system' of the population, concatenated to generate historically intertwined lineages of practices and persons.

Understanding organizational genesis at the level of genotype, therefore, cannot be divorced from understanding the social production of careers and biographies--careers of ideas, of practices and of social relations, as they interleave through the biographies of their person carriers.

An analytic focus on genotype in no way implies that organization is just one individual's blueprint. How logics-of-identity unfold into organization is hardly a matter of automatic template and design.⁵ Actual living organizations,

⁵Likewise, the notion of gene as "blueprint", automatically producing organisms independently of the chemical reaction environment, through which it operates and which regulates it, is discredited in biology.

social or biological, are the developmental products of these founder logics, interacting with the inherent properties of the social or biological raw materials being assembled.⁶ In economic organization, these raw materials in large part are the social networks of business interaction partners, selected into (and selecting) the organization through trading and personnel flows. Out of this soup of founding logics-of-identity and cross-cutting social networks, an autonomous organization will emerge and sustain itself through time if an autocatalytic "metabolic chemistry" of technology and work routines crystallizes out of this ideational/social mixture⁷ (Fontana and Buss, 1994; Padgett, 1997).

This micro, organic view of organization is crucial prelude, both because it defines terms of analysis--namely, logics-of-identity, social network materials, and energetic resource flows; and because it defines a developmental research

⁶In organization theory, institutionalists (e.g., Meyer and Scott, 1983, and Powell and DiMaggio, 1991) more emphasize the first ideational half of this interaction; social embeddedness theorists (e.g., Granovetter, 1985, and Padgett and Ansell, 1993) more emphasize the second 'raw material' half. In biology, Goodwin (1994) and Newman (1994) are especially strong on the second side, emphasizing the channeling impact of organic raw materials on development.

⁷I do not emphasize the point, but in addition a far-from-energy-equilibrium metabolic chemistry, be it molecular or human, needs to be fed with environmentally available resources that it can process (Prigogine and Stengers, 1984). Were I to focus empirically on trading (food) more than on partnership (DNA) this point would assume more prominence.

agenda--how to understand their dynamic interactive unfolding through time. In the Florentine case discussed below, I will be concerned with economic partnership--that is, not with all aspects of the banking firm (employees, trading, etc.), but with the capital-formation nucleus of the firm. In this context, "logics-of-identity" refer to the historically variable rules for capital formation and pooling in Florentine society; and "social networks" refer to the socially structured channels (family, neighborhood, social class, patronage) through which potential bankers with capital found each other to form, and to re-form, firms.⁸

This firm-level, developmental perspective on organizational genesis, while invaluable for clarifying terms of analysis, in the end will prove incomplete for understanding invention. Viewed from the macro perspective of a "market" or a "profession",⁹ the birth or reconstitution of a new firm is just one instance in a larger flow of capital and people through the society's respective market and profession systems. Firm morphology at the level of partnership was and is shaped by the

⁸Because of the focus here on partnership, not trading, the otherwise important role of energetic resource flows (apart from capital itself, of course) recedes into the background.

⁹I place these presentist terms in quotes here, only to remind us that the way Florentines organized "markets" and "professions" bears only some resemblance to what twentieth-century Americans know.

layering of two flows: liquidities of different types of capital¹⁰ and careers of different types of bankers. Overlooking the patterned layering of these macro flows paralyzes us from even approaching the most interesting historical question: how are completely new (albeit path-dependent) and possibly epoch-shaping innovations in organizational form produced? Biologists label this question speciation.

To make progress at this difficult speciation level of analysis requires unfamiliar thought, I will argue, about multiple logics-of-identity, about multiple social networks, and about their concatenation.¹¹ The lives of all people, in all eras, participate in one way or another in economic, in political, and in kinship activities.¹² Societies differ in how they put these domains together. The autocatalytically stabilized logic of recombination in any one sector is regulated

¹⁰By "different types of capital" I mean the sources of capital. In Florentine society, the options were inheritance, dowry, internal past profit, external investment by economically passive investors (aristocrats, churchmen, etc.), and external investment by other Florentine firms. Stock markets did not yet exist, even though government bond markets did, in part because limited liability did not yet exist. The patterns of flow of these different types of capital through Florentine society varied radically, both cross-sectionally and across time.

¹¹In this article, I am generalizing from the one particular, highly centralized, pattern of concatenation of multiple networks with multiple attributions that was analyzed in Padgett and Ansell (1993).

¹²This of course does not imply that all people are thinking simultaneously about all things at every moment.

by the personnel and resource flows produced by other sectors. This I take to be the operational meaning of 'socially embedded' (Granovetter, 1985). More than that, however, occasionally perturbations in one recombinant domain dynamically reverberate, or spill over explosively, into another domain to tip that other domain's own autocatalytic regime.

Descriptively, this is refunctionality: the use of one social or biological organizational form for a completely different purpose (cf. Skocpol, 1976; Sewell, 1980; Stark and Bruszt, 1998). In my observation, such cross-domain rewirings, in the Florentine case often produced in the heat of political crisis, were the catalysts that ultimately generated the most important, epoch-shaping organizational innovations in Florentine economic history. Such economically innovative consequences of political revolt, observed in the Florentine case, were hardly either immediate or inevitable. They occurred only when and if these sometimes violent rewirings became institutionalized into new mating systems, which moved Florentines across domains in new ways, reliably reproducing new types of biographies and careers.

Thus I agree with Burckhardt (1954 [1860]), and implicitly

with Goldthwaite (1968), that Florentine innovation ultimately is to be explained as the social construction of a new type of person. Where I part company with these distinguished and deeply informed judgments is their occasional suggestion that the nature of this new Renaissance person was either modern or individualist.¹³ The economic history I observe in the undeniably innovative Florentine banking industry is, at the industrial level of analysis, neither unidirectional, teleological nor intentional.

Four Phases in the Development of Florentine Domestic Banking

To operationalize the discussion, let me now outline concretely the morphological changes, at the level of partnership, that Renaissance Florentine banking created, from 1300 to 1500, to produce the famous "birth of financial capitalism."

It helps entree into this topic to simplify, indeed to oversimplify, the periodization of Florentine domestic banking into four distinct phases of development: the pre-Black-Death era of family banking (...-1348), the pre-Ciompi-revolt era of guild banking (1349-1378), the post-Ciompi era of *popolani* social-class banking (1380-1433), and the Medici era of

¹³But see Goldthwaite (1983, 1987) for a modification of his earlier (1968) position.

patronage banking (1434-1494). While this timing is defined primarily on political lines, economically based domestic banking partnerships had very distinct organizational profiles in each of these political eras. It is an oversimplification to interpret the relationship between these periods as phase-transitions--namely, as sharp breaks where one mode of organization completely superceded and transcended prior modes. The path-dependent biological metaphors of sedimentation and induction, where new organizing modes arise on the shoulders of, to remobilize and to recast, older historical "residues", is closer to the actual truth. Nevertheless, simply to introduce the distinctive Florentine developmental trajectory I will here map out a succession of ideal types. These four idealizations all have distinctive organizational, market-structure, cultural-meaning, and social-embedding components, which together point the way to how economic banking markets were rooted in their broader, changing social context.

From the 1200s dawn of Florentine international banking in the Commercial Revolution (Lopez, 1976) to the political, economic, and demographic crises of the 1340s, the organization of Florentine domestic banking was dominated by the family. At the turn of the century, when my guild registration observations begin, fully 80% of Arte del Cambio partnership dyads were among

members of the same family.¹⁴ Guilds existed and were politically active, but at the level of internal bank organization they had not yet displaced family as the social logic of partnership.

Partly because patrilineage itself in this late-medieval period was often large and solidary, banks in this era grew to larger sizes (measured either in capital or in number of partners) than did any banks subsequently. Banking was just one of many activities in the diversified portfolios of patrilineages.¹⁵ Because of this, economic "capital" (revealingly called *corpo*) assumed the cultural meaning of the social raw material out of which banks were constructed: it was considered "patrimony", to husband, to nurture, and to pass down through the generations, like land. Career mobility between banks was essentially zero, with the result that banks simply were born, grew, and died--no mergers, recombinations or splintering (until death of father).

Market "competition" had a Darwinian feel: sometimes harsh death-rate selection pressure within various customer niches, but little cost-cutting or explicit coordination between banks.¹⁶

¹⁴Operationally, "family" here means either same surname (indicating lineage, not nuclear family) or, if no surname existed (e.g., only "Giovanni son of Paolo"), same father.

¹⁵Other activities being land, Church, political competition and physical violence.

¹⁶Albeit about a later period, Goldthwaite perceptively has observed: "[Florentine] merchant

Exchange relations between banks, to the extent they could not be avoided altogether, were managed through notarized contracts, because families deeply distrusted each other. Relative to subsequent phases, banks preferred to operated autonomously, developing corporate organizations with vertical integration (linking trade, bills-of-exchange, and diplomacy), if possible.

In virtually every economic aspect above the lowest level of pawnbrokers and mere money-changers,¹⁷ in other words, the logic of Florentine banking organization was colored by the logic of patrilineage during this late-medieval period.

Through a political process described below, patrilineage throughout Florence weakened,¹⁸ for reasons having little specifically to do with banking. Guild moved from the background

bankers undoubtedly competed with one another for the sale of their goods and the attraction of clients--but not to the extent that they devised techniques for product variation and cost-cutting in their home industry and for underselling and market domination abroad.” (1987, 23)

¹⁷ Pawnbrokers and money-changers were too small to require any partners at all.

¹⁸ Among Arte del Cambio banks, the percentage of family-based partnership dyads dropped from 80% to about 40% during the period of 1300 to 1340. [Note that the timing of this drop long preceded the 1342 banking crisis so discussed in the literature (Sapori, 1926).] These numbers may help to adjudicate the debate about family in Florentine historiography between Goldthwaite (1968) and Kent (1977). The existence of decline supports Goldthwaite’s position, although the timing is earlier than the period Goldthwaite analyzed. But 40% is still a large number. This fact thus supports Kent’s point about the continued importance of Florentine family throughout the Renaissance. Looking closer at the Arte del Cambio numbers reveals that the 1300-1340 decline was disproportionately due to the virtual disappearance of father-son partnerships. Partnerships between brothers, and to a lesser extent between cousins, remained common throughout the 1300-1500 period.

of regulatory control to the foreground of socially constituting partnerships. Not only lower-level employees but also partners themselves formed and reformed themselves according to a logic of master-apprentice, displacing the earlier logic of father-son. This implied internal hierarchy: large experience and *corpo* differentials between non-family partners, socially anchored very frequently in cross-class neighborhood relations.¹⁹ But it also implied social mobility: the goal of the apprentice was artisanal autonomy, with the consequence that firms constantly splintered. Apprentices hived off to become either solo operators or masters of new apprentices.

The market-structure consequences of this newer guild-based firm-formation logic are straightforward. Due to constant fissure, firm-size distributions were deconcentrated in the extreme. In the 1348-1376 guild era, one to three partners in Arte del Cambio banks was practically universal; in contrast, seven to twenty partners was not unusual in the preceding patrilineage era. Due again to constant fissure, career mobility ties among firms were dense; one's competitor could be one's ex-apprentice. In this context, deconcentration was more a

¹⁹As in "take on your lower-class neighbor's son" first as apprentice and then, if that works, as partner. The terms of the partnership contract often compensated the subordinate partner for their extra labor with share of profits greater than the share of capital contributed.

reflection of community solidarity than of neoclassical perfect competition.²⁰ "Capital" is best conceived in this regime as a personal-career "stake": the goal of the artisan was to carve out a good life for himself, not necessarily to maximize profits.²¹ Within ranges, wool-firm production levels were chosen not individually by firm but collectively by masters in their guilds (Najemy, 1981). Account books, not typically double-entry, displaced contracts and notaries as the medium for inter-bank exchange, since now bankers could trust each other enough simply to walk across the *piazza* (located either in Florence or in another city) jointly to clear their books.

After the 1378 *Ciampi* wool-workers revolt, guilds

²⁰See McLean and Padgett (1997) for formal statistical tests of the neoclassical perfect-competition model for Florence, using primary data on thousands of transactions collected from the 1427 catasto. These tests in particular reject the neoclassical hypothesis of impersonality in exchange. Of course some economists recently, including those in this volume, have moved beyond the textbook neoclassical assumption that the only things that matter in exchange are price and quality of goods.

²¹Indeed without double-entry bookkeeping (invented by the time of, but not used much in, the guild period), the concept of 'profit' was hard to measure precisely, at least on an ongoing basis. Indeed, even modern historians as distinguished as Saporì and de Roover can differ widely in their calculation of fourteenth-century 'profit rates', using the account books of the period (de Roover, 1958). When partnerships dissolved, there was an accounting of profits, in order to split proceeds and settle debts. But before partnership dissolution, while the bank legally operated, overall accountings were not regularly performed. This is not to say that during the guild period partners had no informed "rough and ready" sense of how things were going in general. But theirs was a detailed knowledge of specific transactions ("tacit knowledge"), highly dependent upon the personal expertise of the partner. Guild-style bankers certainly cared about making money, but there was no social need in such a highly personalized context for the measurement of relative performance as objectified "profit".

effectively were crushed, due to their role in this political crisis. The *popolani*²² as a social class moved in to dominate partnership in all major Florentine industries, in a way quite analogous to their republican domination of politics in this same era. The consequences for partnership formation of this embedding of banking into social class were the following. Within domestic banking itself, class endogamy became the soil out of which sprang a hybrid family/nonfamily partnership form, with a nucleus of brothers or cousins surrounded by a periphery of same-class partners, into whose family the brothers or cousins often married. Even absent formal marriage, *amicizia* or friendship relations were central. "Family" therefore reemerged in banking partnerships, but in the looser horizontal *parentado* sense of marriage in-laws (and close friends), not in the vertical patrilineage sense of father-son. In capital accumulation, dowry and credit grew in importance, relative to inheritance.

Perhaps even more profound were the cross-industry

²²Social classes in Renaissance Florence were defined in terms of political age of the family. In particular, the date at which one's ancestors first were selected to serve on the governing city council (the *Signoria*) was a publically known fact, measuring one's family's prestige. Analogous to Boston Brahmin descendents of the Mayflower, the *popolani* were the most prestigious social class in Florence, whose ancestors controlled the Republic from its founding in 1282 until Walter Brienne, the Duke of Athens, in 1343. Thus the term "social class", as I use it, refers to status, not to wealth or to occupation.

consequences of *popolani* dominance. In the guild regime, intra-industry career mobility was high, but cross-industry career mobility was low. In contrast, the post-*Ciampi* period witnessed an efflorescence of cross-industry organizational "systems",²³ of which the diversified conglomerates of Francesco Datini (the merchant of Prato) and of the Medici are the most famous. In particular, there was an explosion of partnership links between overseas merchant-banking firms and their domestic banks counterparts, although wool and silk manufacturing firms were included in these organizational systems as well. Perhaps for the first time it is legitimate to think of "capital" in the modernist sense of "investment", albeit investment only among closely linked companies.²⁴

Even more extensively knitting together firms than partnership systems were the open-ended credit relations that developed within the core of the Florentine banking industry at this time. Standing cross-accounts and the standardized protocol of double-entry bookkeeping were now the technical mechanisms facilitating this explosion of unsecured credit, backed 'only'

²³The somewhat vague term "systems" is due to Melis (1962). De Roover (1966) calls these cross-industry organizational systems "holding companies", but what they were really were networks of overlapping but legally-separate partnership contracts, coordinated by centrally placed partners in each of these contracts.

²⁴There was no such thing as a stock market. That was invented later by the Dutch and the

(but all importantly) by trust and reputation.²⁵

It is no doubt an exaggeration to impute the goal of "domination of the market" to individual entrepreneurs of this era, if only because this was still far beyond their organizational capacity. But clearly there was a "visible hand" managerialist logic of coordination and control across multiple markets and firms not present in earlier phases. And the power-drenched reality of "domination of the market"--institutionalized politically in republican balie and in near-monopoly by *popolani* of guild-consul and Mercanzia offices--was in fact achieved at the level of social class, if not at the level of individuals. Banks and banking during the *popolani* oligarchic era were constructed on the social infrastructure of politically inspired elite-construction mechanisms--intermarriage, *amicizia*, and emergent clientage.²⁶ Such organizational innovations generated economy-wide, not just industry-wide, financial elites.

While organizational developments in economics certainly can not cause ideas, this third *popolani* phase is the economic-

British, in major part for political reasons (Carruthers, 1996).

²⁵Melis (1962) in particular heavily emphasizes the role of *fiducia* in the banking of this period. See also Goldthwaite (1987).

²⁶Brucker (1969: chapter 3; 1977: chapter 5) in particular has emphasized the explosion of *amicizia* and clientage during this republican period.

cum-political backdrop to the famous ideological construction of civic humanism during this same period (Baron, 1966). Civic humanism imparted to the new economy-wide elite a deep self-consciousness about its own importance in Western history (cf. Emirbayer and Goodwin, 1994).

In the post-1434 Medici era, developments in domestic banking are only imperfectly revealed, because of an unfortunate gap in the Arte del Cambio records. One major clue, however, is unequivocal: the social class composition of domestic bankers, as well as of partners in other industries, shifted dramatically from overwhelming *popolani* domination to an equal distribution between *popolani* and "new new men" (a parvenu class of families defined by their entrance into the Signoria after the *Ciompi* revolt). In the case of domestic banking, this compositional shift was not gradual: it occurred immediately upon the accession of Cosimo de' Medici. And in the case of domestic banking, this shift was not accidental: new matriculation data reveal virtually an affirmative-action policy of equal rates of admission into the guild. In short, all signs point to an implementation of exactly the same Medicean political control strategy for banking that Eckstein (1995) has uncovered for neighborhood *gonfaloni* during this same period. I have already analyzed the emergence and effectiveness of this "class

balancing" Medicean control technique in the pre-1434 period (Padgett and Ansell, 1993).

It is an inferential leap to jump from this clear evidence of social class composition to an interpretation of domestic banking under the Medici as "extreme patronage" in logic.²⁷ Nevertheless, a series of collateral data make this interpretation plausible at least as a working hypothesis: (1) Louis Marks (1960) has demonstrated the emergence of a Medicean "financial oligarchy" in the domain of state finance, with extremely personal and highly politicized linkages between high-level financiers and the emergent Medici court. (2) The Medici demonstrated unequivocal patronage behavior towards lower-level Jewish pawnbrokers (Fubbini, 1996), whom the Medici brought into Florence soon after their accession, and who were evicted from the city by Savonarola immediately upon their 1494 fall. (3) The functional segregation between domestic banking and the government bond market broke down under the Medici, as an explosion of Monte commune and dowry-fund *prestanze* (forced loans) unleashed a secondary market of speculative trading in discounted bonds (Molho, 1994), in which domestic bankers

²⁷I distinguish extreme patronage from patronage by the social (and wealth) distance between the parties. Patronage in the *popolani* period linked near equals; hence, it was cognitively and linguistically very close to *amicizia* (McLean, 1996). Patronage in the Medici period, in contrast,

participated heavily (Goldthwaite, 1985). (4) The Medici mobilized domestic bankers into their extra-constitutional financial advisory committees, to reform taxes, the mint, the Jews, and other pressing financial matters (Marks, 1960; Brown, 1992). All these pieces of evidence, while external not internal in character, show the same progressive Medicean entanglement of banking into state fiscal administration.

If this extreme-patronage interpretation of domestic banking under the Medici proves correct, then we should witness, on the economic front, a progressive separation of finance from entrepreneurship. Instead of inter-industry organizational systems, in which managerialist elites control multiple markets, high-level financiers withdraw into the state, reaching out to remaining entrepreneurs through short-term, more speculative loans. Even domestic bankers themselves can become "clients" in this dynamic. In actual historical fact, domestic banking under the Medici became far more stratified than before, with a few highly successful and long-lived banking firms, sitting on Medici advisory committees, being offset in ratio within the Arte del Cambio records by many more small, purely local, impoverished firms, these latter with relatively poor economic prospects outside of bond-market speculation.

linked people of vastly different social statuses, more akin to *magnificenza* (Jenkins, 1970).

Thus in the paradigmatic case of Renaissance Florence, it appears to be the centralizing court, not liberal laissez-faire, that spawned the emergence of highly specialized classes of financiers (both wealthy and impoverished), differentiated from production and trading, and relating to business primarily through immediate, short-term gains.²⁸ Although further research into this question is required, it appears that only in the Medici period did finance become segregated into different organizations from those for business and trading. Before this period, 'merchant-banker' is a more accurate term than just 'banker' alone.

Partnerships and Careers

In this "birth of financial capitalism" narrative, the most glaringly obvious empirical fact is the temporal covariance of political and economic transformation. It is the inner logic of this covariance that most needs analysis. To proceed, I will

²⁸A second historical factor, not accounted for within this extreme-patronage interpretation, is the fact that many republican merchant bankers and their families were politically exiled, without necessarily destroying their overseas business firms thereby. (I thank Richard Goldthwaite for this observation.) The Strozzi family (Gregory, 1997) is one clear example. [The Alberti family (Baxendale, 1991) is a counter-example, where political exile really did hurt their overseas business.] Political exile is a dramatic and obvious blow to "system" partnership ties linking foreign and domestic branches. Given the unprecedented magnitude of Cosimo's exile policy, it is even possible that this political policy negatively affected the economic integration of the Florentine domestic economy into at least some sectors of European international trade.

follow the biologically inspired framework sketched above and break the organizational genesis problem down into three levels of analysis: first, a micro 'genotypic' level of analysis, in which the central issue is how organizational sequences are produced through the interweaving of careers; second, a mezzo 'developmental' level of analysis, in which partnership mating is regulated through social and political network-embedding; and third, a macro 'speciation' level of analysis, in which the central issue is how social-network rekeying of logics-of-identity is accomplished, across political-cum-market regimes. This section of the article focuses on genotypic mating; the next section focuses on developmental regulation; the last section focuses on speciation.

Each of the four phases of Florentine domestic banking history rested on a distinct institutionalized conception of what a partnership was: its logic-of-identity. Banking organizations (at least their partnership cores) were the unfolding and concatenation of these building-block elements through time.

In figures 1-4, I represent prominent examples of these partnership conceptions graphically. There, bankers are represented as vectors of two components: economic capital (*corpo*) and human capital (years of banking experience). In both

cases, the notation '+' means large amount of capital possessed; '½' means small amount of capital possessed; and '0' means no capital possessed. Partnership relations are represented as different matching profiles or capital complementarities between the two bankers' vectors. Which match between capital vectors is 'complementary' depends upon social embedding--that is, on the underlying social relation that spawned the partnership. Economic viability constraints are built in to the representation through the requirement that the sum of economic capital and the sum of human capital must each equal at least 1 (or '+').²⁹

(1) In the family regime, the distinct logic-of-identity was lineage father-son; hence the network of partnership recruitment was patrilineage. In figure 1, father-son is represented as a match between the two capital profiles: father's C/E=(+/+) and son's C/E=(0/0). Their personal feelings aside, father-son formally is an altruistic relationship where someone who has everything sponsors (or 'makes') someone else who has nothing.

Figure 1a shows how, in a patrilineage regime, such father-son relationships typically unfolded and concatenated through

²⁹In a more formal representation, both these capitals of course would be made continuous.

time, to generate the life history of a patrilineage bank. Such banks developmentally were produced through simple agglomeration: father-son firms started small, and kept growing larger through adding more and more extended family members, until sooner or later disaster caused bankruptcy and massive collapse.³⁰ Authority within the firm, among partners, was hierarchical not equalitarian. Career advancement was generational; sons had to wait for fathers' death and inheritance. Inter-firm employment transfer, to another family, was virtually unthinkable; hence the economic fate of the banker was tied to his firm.³¹

Figure 1b shows the analogous logic for brothers, more appropriate for nuclear than for patrilineal families. Empirically, brother-brother firms existed throughout Florentine banking history, unlike the father-son firms which were mostly contained in the patrilineal period. Brothers would often split up and divide their inheritance, including the bank, upon the death of their father, whether or not the father was active in the firm (Kent, 1977; Goldthwaite, 1983). I label as strong

³⁰Of course, extension in this way is dependent upon underlying family structure: *popolani* and *magnati* extended clans were inherently capable of growing larger firms in this manner than were the more nucleated families of the new men.

³¹The prevailing legal doctrine of unlimited liability, of course, made much sense in this social context.

brotherhood the variant where brother partnerships lasted beyond the death of the father, and as weak brotherhood the variant where it did not.³²

Note that all the figures 1 through 3 can be read in two ways: (a) as bankers coming together under different partnership logics to produce life histories of firms, and (b) as life histories of firms developing bankers' careers. This double reading is an example of the network-analysis concept of duality (Breiger, 1974). Duality is the network architecture through which markets socially construct persons.

(2) In the guild regime, the distinct logic-of-identity was master-apprentice; the social network of recruitment primarily was neighborhood, typically cross-class. A master differed from a father in requiring his apprentice to gain some experience (usually, though not necessarily, under himself) before promoting him to partner. Also, the expected duration of the partnership was shorter: instead of 'until death do us part,' apprentices typically wanted to become independent masters as soon as they were capable of sustaining economically viable firms. Other than that, masters and fathers were similar: both

³²I suspect, but have not yet confirmed to my own satisfaction, that the strong brotherhood mode is characteristic of the lower social classes, while the weak brotherhood mode is more characteristic of the upper social classes.

had hierarchical authority, grounded in their superiority on both *corpo* and experience fronts.

Figure 2 illustrates graphically the consequences of concatenating this social logic through the life history of a firm. Developmental sequence of guild banks was repeated schism, as 'apprentice' partners build up enough wealth and experience to declare independence by starting their own firms. Empirically I have observed that *popolani* and *magnati* bankers behaved differently in their later-life stage as fully-autonomous masters: experienced masters of *popolani* and *magnati* social class backgrounds continued to sponsor young lower-class apprentices as partners, while experienced masters of lower-class backgrounds (new-men, new-new-men, and no-date) preferred to become solo operators. The net result was a loose pecking order among guild masters: Cambio masters of *popolani* and *magnati* background disproportionately reproduced bankers of all social classes.³³

Loose pecking-orders notwithstanding, relations among banks were personal and solidaristic. Not only was this market structure grounded socially in the daily practice of bankers

³³Guilds, in other words, while truly motors for social mobility, were also mechanisms for *popolani* masters' control over the other masters so admitted. The 1378 *Ciompi* revolt uncovered vulnerabilities in this particular mechanism of control.

sitting around the same *piazze* every day, as mentioned above, but also the same career logic that generated guild banks also produced biographies of dense ex-partnership ties among competitors (who as a result were not all that competitive).³⁴

(3) In the *popolani* regime, the distinct logic-of-identity was social class; hence the network of partnership recruitment was intermarriage and elite *amicizia* (friendship). Figures 3a and 3b illustrate the capital-complementarity consequences for partnership.

The intermarriage variant of social-class logic is presented in figure 3a: the father-in-law gives a dowry to son-in-law, who uses that as *corpo* in a partnership either with father-in-law himself, if father-in-law himself is in the same industry, or else with a friend of father-in-law, if he is not. Son-in-laws had more *corpo* actually in hand³⁵ than did sons, who relied instead on future inheritance. This greater wealth gave to son-in-laws more clout in the partnership than sons or apprentices had, but they remained subordinate.

As shown in figure 3b, the *amicizia* variant of social-class logic produces, for the first time, an asymmetry in capital

³⁴Modern-day industrial districts come to mind as contemporary analogues.

³⁵I leave aside the complications Florentine son-in-laws sometimes experienced in collecting their dowries.

complementarity: the partner superior in *corpo* is not necessarily also superior in experience. The logic of 'friends' is to help each other out in need, in the sense of giving to the other what the other lacks. Applied to partnership, this logic implies the exchange of *corpo* for experience. Applied to loans, this logic implies a heavy reliance on unsecured credit and loose repayment schedules,³⁶ although of course only among friends with solid reputations.

In-law and *amicizia* relations vary in duration: a father-in-law relation lasts until the death of the wife, whereas a friendship relation varies widely in duration. Likewise the degree of equality in *corpo* can vary. One tends to assume that son-in-laws are less wealthy than father-in-laws, but dowries in the Florentine elite sometimes reached uncomfortably high levels, from the perspective of the father-in-law. Similarly, one tends to assume that friends are roughly equal in wealth, but Florentine friendship readily bridged wealth differences, perhaps because of the extreme wealth disparities both within social class and within family itself. The point is that building partnership on the social-class foundations of

³⁶The concept of 'friend' is not so elastic as to imply no repayment at all (pure gift), but it is elastic enough to allow 'repayment' in numerous social currencies. The post-1420 Medici were well known for repayment of their economic loans in political currency (Molho, 1973).

intermarriage or friendship automatically introduces more flexibility in duration and in relative authority than can exist in the patrilineage or the guild context.

A second, historically crucial consequence of a shift of economic partnerships onto social-class foundations is the automatic opening of the door to cross-industry ownership connections. Given Florentine fathers' bias in passing down their occupation to their sons, in-laws and friends were more likely to be in different industries than were relatives (and by definition than were fellow guildsmen). Both *parentado* and *amicizia* naturally generated cross-industry partnerships, once they became mobilized into economic activities.

(4) I will not sketch the Medici period in the same detail here because of the gap in Arte del Cambio records mentioned above.³⁷ In the overall summary figure 4, however, I illustrate the capital-complementarity meaning of extreme patronage: patron's C/E=(+/0) coupled with client's C/E=(0/+). This is extreme asymmetry in partners' *corpo* and experience: a wealthy financier, with no knowledge, sponsoring a poor entrepreneur, with no wealth.

Brucker (1969, 1977) is the historian who most persuasively

³⁷Filling this gap will require me to find new primary sources.

has emphasized both the pervasiveness and the flexibility of the Florentine concept of patronage--extensible from the relatively equalitarian overtones of *amicizia* in the republican period to the sharply hierarchical emphasis of *magnificenza* in the Medicean period. Sharp economic and political organizational changes were likely built, in other words, upon a social ground of cultural and linguistic continuity.

Organizational Identity and Control³⁸

In each of these phases, role was framed by identity (Goffman, 1974: 293-300). That is, Florentine bankers' understanding of what it meant to be a partner was affected, in each of these periods, by their conception of themselves as persons, outside of the bank. Social embeddedness, however, is not mere social determinism, because who bankers were outside of the bank was distinctly non-obvious. It is not as if bankers in all four periods were not simultaneously fathers, neighbors, friends, and patrons.³⁹ They were all of these things all of the

³⁸This heading is meant as a reference to Harrison White's book Identity and Control (1992), in deference to the early training and wealth of ideas I received from White, while I was an assistant professor. This article shares with that book a concern with similar themes, although the mechanisms are different.

³⁹Based on their dairies, Christiane Klapisch-Zuber (1985: chapter 4) paints a marvelous portrait of this multiplicity of relations for the Niccolini family in Renaissance Florence. My only quibble with her insightful analysis would be to draw a sharper distinction than she does

time. Multiple, overlapping social networks shaped banking because they defined the generative context or raw material out of which banks emerged. But for an even deeper explanation of organizational genesis, we need a yet-to-be-specified identity-construction mechanism that leverages banking into one or another aspect of its surrounding social context.

From the Florentine evidence, this mechanism appears to be political in character. Most authors discuss "identity" and "framing" in cultural or linguistic terms. Here too there is a linguistic aspect to the story. In my opinion, however, more fundamental than language for banking was how Florentine political institutions shaped actual (not just interpreted) biographies. Biographies are different from careers in that the concept of careers refers to life sequences within a single domain of activity (economic, political, family), whereas the concept of biography refers to life sequences across multiple domains (interleaving economic, political, and family). If they were smart, bankers, when constructing their own biographies (as opposed to careers), needed to attend to how other Florentines rewarded or punished moves in one domain in the currency of

between friend and godparent, the latter to me being more like patron. Klapisch-Zuber herself admits (p. 89) that the Florentines themselves did not equate these two categories. Friend was typically intra-class, whereas patron was typically cross-class; but of course, as I too emphasize above, these blended into one another.

other domains. For example, a move in economics shaped family options; a move in family shaped political options; a move in politics shaped economic options; and vice versa around the causal loop. In Florence, clear distinctions between domains were blurred precisely because of the strength of such interaction effects.

No activity inherently took priority in Florentine consciousness: the pursuit of wealth, status, and power all were important. It is especially important in an article on banking to note that banking was not necessarily a life long activity: the average length of a career in domestic banking during the guild and *popolani* periods (1348-1399) was 8.21 years,⁴⁰ according to Arte del Cambio records. But of course similar things could be said about politics and even family. Rather than arguing which was more important, the main point is the multiplicity of Florentine activities and concerns.⁴¹

In this multivalent context, which of the aspects of their external lives were selected as identities to be relevant for bankers' attainment and maintenance of their current position as

⁴⁰This figure does not correct for truncation effects. The 1348 Black Death makes left-hand truncation largely irrelevant. But right-hand truncation post-1399 makes 'about 9 years' probably a more accurate statistic.

⁴¹This is a central argument in Padgett and Ansell (1993). See also Weissman (1989). For the contrasting presumption that medieval Italian state-formation was driven primarily by an

bankers? The answer to this question has two parts: (1) Since partnerships are dyads, not single individuals, the identity of one party to a relation is as much the selection of the alter as it is of the ego: identity is negotiated, not chosen.⁴² As such identities are rooted in matching processes. And (2) the micro-terms of dyadic negotiations are not usually idiosyncratic; they are grounded in public discourse by institutionalized rules of access, which shape the terms of translation between multiple domains.

Recruitment systems reproduce regimes of identity, once they are already in place. New bankers are recruited or sponsored by existing bankers, through the same networks that existing bankers experienced as the reasons for their own success. An industry thereby selects those aspects, or identities, of the multifaceted persons of entrants that it deems relevant to the types of banks it makes. Viewed microscopically: who you become as the person behind your banking role is which of your pasts the industry has made into

economic logic, see Greif (1994).

⁴²Compare Leifer (1988). Note that this formulation of the concept of 'identity' denies any essentialist connotation: 'Identity' is the cognitive person-framing of person-role interactions, not a fixed psychology located deep within people. In the context of economics, for example, the identity of a banker could be 'father'. But in the context of the dinner table, the identity of a father could be 'banker'. This relativist interpretation is consistent with White (1992), who in turn takes seriously the decades of research in psychology about the weakness of sustained

the reason for your coming to occupy that role. Compositionally, this does not imply social homogeneity, as many filtering arguments suppose, because recruitment networks are not necessarily closed. But it does imply industry convergence on some rather than other dimensions of classification of heterogeneous personnel.⁴³

Recruitment systems typically are anchored in elites. Even if new entrants to an industry are heterogeneous, the very process of moving them up into the core of that industry transforms multifaceted human material into the classifications of the core.⁴⁴ Clear, univocal personal identities thus are the consequence of tight social control.⁴⁵

Elites themselves experienced their own incorporation numerous years in the past. In stable regimes, therefore, elite-policed personnel matching systems reproduce control patterns laid down in the past. In unstable regimes, conversely, either

empirical evidence for anything like a stable core 'personality' (Mischel, 1990).

⁴³To paraphrase Mary Douglas (1986), institutions do the thinking, although I would be quick to add not necessarily only through the culturalist mechanisms she emphasizes. For a quite different application of this identity from mobility-as-control argument in the setting of the U.S. Congress, see Padgett (1990).

⁴⁴Najemy (1982, chapter 8) offers a profound analysis of post-*Ciompi* Florentine electoral reform along these lines. March and March (1977) give a similar argument, albeit in the completely different terminology of mathematical statistics.

⁴⁵From radically divergent normative premises, White (1992), Janowitz (1991), and Gramsci (1971) all would agree with this conclusion. The converse of this point--namely, that effective

political conflicts or interruptions of economic mobility can disrupt the smooth operation of organizational reproduction and set the stage for morphological rekeying. Either way, the memory of past historical fractures becomes layered into current network structure.

This internalist reproduction mechanism applies equally well, with different social network content, to each of the four phases of Florentine banking development. As such, social matching/recruitment systems alone cannot explain differences among them. Besides path-dependent reproductive matching, at the level of careers, however, the second answer to the identity-construction question is translation, at the level of biography. "Rules of translation" and "protocols" are concepts that apply not only to language and to software. How people are moved across different activity domains is "translation" in social structure. As in linguistics (cf. Duranti and Goodwin, 1992), where a person or text is coming from, and where it is going to, are crucial for the indexical interpretation of the current multivocal person or text.

For biography, translation means access. In the short-term time frame of making public-policy decisions, bankers may need to translate their problems into terms that can compute in the

control over others is rooted in multivocality--has been developed in Padgett and Ansell (1993).

public arena. In the longer time frame of a biography, bankers may need actually to enter the political arena.

In the late-medieval era, patrilineage (aggregated into fluid factions) was the core recruitment network into Florentine political office. Guild succeeded patrilineage during the so-called guild-corporatist regimes of the early Florentine republic. The *popolani* logic of state service undergirded the Albizzi 'consensus' republicanism of 1378-1434, so celebrated in civic humanism. And loyalty to the Medici party determined political access after 1434, institutional appearances notwithstanding.⁴⁶ By 'political access' here, I mean the actual (albeit changing) legal rules for eligibility to and for voting for offices in the Florentine republic. Repeated struggle over these inclusion rules, between new and old cohorts, was what domestic politics in the Florentine Renaissance was largely about (Brucker, 1962, 1977).

Patrilineage, guild, social class, extreme patronage--viewed from the perspectives of politics and of economics simultaneously, these identities were protocols through which politics and economics communicated. Najemy (1991) has made the perceptive observation that Florentine political institutions

⁴⁶These enormously simplified summaries can be fleshed out with Najemy (1982) and

are better understood as dialogues of power between contending groups, than as instruments of domination by any one. Here I extend the point to individuals: personal identities are micro-institutions that enable economic, political, and family roles to communicate. 'To communicate,' moreover, in two senses: (a) to permit actions in one domain to be interpreted in another, and (b) to allow human beings to move readily across domains.

When does all this matter for actual bankers? The answer is in a pinch. Quite apart from the reality of multiplicity of goals, firms faced with bankruptcy often needed to reach into their bankers' political and familial networks to stave off disaster. Concretely, this meant that in the patrilineage regime, bankers had to become *Bardi* (or whatever their family name is) in order for politics effectively to understand their plea for help. But in the guild-corporatist political regime, bankers had to become Cambio guildsmen to be effective. And similarly, they had to become *popolani* or Mediceans for effective translation of their economic requirements into the politics of different regimes. Bankers of course were free not to play this game, but then their chances for economic survival were greatly diminished, especially during times of crisis.

Paradoxically, this does not imply that bankers needed to

Rubinstein (1966), which are the definitive histories of electoral reform in Florence.

reason self-consciously as politicians. Quite the opposite: to the degree that bankers' understanding of their own identities converged with institutional definitions, they were free to behave 'naturally' (that is, without profound self-reflection) in political arenas and 'naturally' in economic domains, leaving their politics at their bank-office door. Cross-domain translation, embodied in person-role framings, is performed for the most part socially by recruitment and access systems; 'mind control' over each and every individual certainly is not required for system reproduction of individual identities.

In each of the four Florentine banking regimes, the "person" behind the banking role became whichever political identity was necessary to maintain both the role and one's occupancy of that role. As a consequence, as the elite access rules linking markets and politics changed, so did the logics-of-identity framing of elite banking roles.

The recruitment and the translation mechanisms for the construction of identity operate similarly in the sense that both are institutionalized methods of control that select the features of the person relevant to entering and maintaining his or her position. As such, to the extent that people learn the reality of how they are treated, I argue that a person's cognitive understanding of their own identity is less an

infinitely flexible interpretation than it is a socially constructed fact.⁴⁷

The Coevolution of State and Market

Now to the hard question of speciation: what are the dynamics of transition between banking regimes (here, from family banks to guild banks to *popolani* systems to extreme-patronage finance)? This question is so challenging that I can not pretend fully to answer it here. But we at least shall begin, with discussions of the family to guild transition, during the first years of the republic, and of the guild to *popolani* transition, during the *Ciampi* revolt. The political side of the *popolani* to Medici transition has been discussed at length in Padgett and Ansell (1993), and so receives more cursory treatment here. These discussions will concentrate on the changing roles and identities of merchant-bankers, rather than attempt in this brief compass to focus equally on all groups.

The core of my interpretation of these fundamental

⁴⁷Depending upon the details of multiple-network structure, such learning can lead toward sphinx-like multiple identities, as in the case of Cosimo de' Medici (Padgett and Ansell. 1993), as well as toward the more clear and univocal identities emphasized here.

Florentine transitions will be as follows:

(a) During the early years of the republic, merchant-bankers reacted to threatening magnates (themselves organized as patrilineages) by reaching out politically to prosperous immigrants through guild corporatism. Over time, this originally instrumental move transformed their own identities from patrilineages into Cambio (and other *arti maggiori*) guildsmen.

(b) During the *Ciampi* revolt, merchant-bankers reacted to the threatening *Ciampi* (themselves organized by guild aspirations) by reaching out politically to other economic elites through civic republicanism. Over time, this originally instrumental action transformed themselves from guildmen into *popolani*.

(c) During the 1425-30 Milan and Lucca wars, the Medici merchant-bankers reacted to threatening oligarchy (defined as *popolani*) by reaching out politically to new-new men through San Giovanni patronage, thereby transforming themselves into a Medicean political party.

In all three cases of regime speciation, the transition rhythm was roughly similar: (a) a constant background of new (and exiled) persons demanding political and economic inclusion; (b) war and/or economic shock; (c) polarization of the political system along lines of cleavage inscribed into the previous institutional order; (d) spillover of polarization, if intense

enough, into a few cross-cutting odd bedfellows; (e) conservative reaction by merchant-bankers to the threat posed to their business, through reaching out politically from within the fractured elite to groups defined in complement to the threat; (f) victory, purge of losers, then re-consolidation of a new regime, which was characterized legally by transformed identities layered on top of the old ones.⁴⁸ Then, after a generation or so, some version or other of the sequence repeats. In political science, this process of changing political-identity dimensions is called realignment.

The net effect of these transformations (in the case of Florence at least) was the preservation of most, but not all, merchant-bankers in a position of power.⁴⁹ They adaptively shifted their alliances and modes of access in political dialogue with varying others, in a defensive effort to preserve who they were. An unintended consequence, however, was that 'who they were' itself changed, with all the attendant consequences for the organization of banks that implied.

⁴⁸Old identities were never abolished; they just retreated in salience into the background.

⁴⁹Perhaps this is one reason for the remarkable continuity of many famous Florentine families, in the face of the economic and political turbulence of Renaissance Florence. This familial continuity has been most astutely analyzed, from the perspective of marriage, by Anthony Molho (1994).

Each of these transition sequences was initiated by a war and/or economic shock:

(a) The 1282-93 foundation of the republic, on the basis of guild corporatist ideology, was initiated by defeat of the Florentine Ghibellines in a civil war, coupled with a boom, not a crisis, in the Florentine economy. This boom came from international trading through the Guelf alliance (Schevill, 1961). Florence was larger and more prosperous in this turn-of-the-century patrilineage era⁵⁰ than at any time subsequently (Villani, 1844 [1350]).

Wars between England, France and Flanders, however, caused sharp retrenchment in the banking industries all over northern Italy during the subsequent 1300-1343 phase (LaSorsa, 1904; Saponi, 1926; Kaeuper, 1973; Housley, 1982; English, 1988). Internationally-oriented bankers took advantage of their newly ensconced Arte del Cambio and Mercanzia political positions to crack back economically on purely domestic money-changers and bankers, through strict enforcement of guild regulation (Najemy 1972; Astorri, 1998).⁵¹ Hierarchy was established within guilds,

⁵⁰As explained above, banks were still overwhelmingly family-based in 1300, in spite of the brand-new guild-corporatist state framework. Bank partnerships themselves only absorbed political guild-identity in their economic logic in reaction to the 1300-1343 macro-economic decline.

⁵¹Florence's rigorous self-policing of debts through the state stands in marked contrast to the

and the raw numbers of Florentine bankers shrank, as free entry to the industry was abolished. Bankers' strictly instrumental political behavior in 1283-92 as guildmen gradually became infused, by 1343, into their own economic-cum-political identities.

(b) The 1378 *Ciompi* revolt was immediately preceded by the 1375-78 War of the Eight Saints with the pope and by a sharp decline in the wool industry, perhaps caused by papal interdict, perhaps not (Trexler, 1974; Hoshino, 1980). The War of the Eight Saints, itself the product of a bitter domestic struggle between magnates and new men, which was centered around political persecutions by the Parte Guelfa (Brucker, 1962), destroyed forever the pro-papal Guelf alliance.

Environmental shocks, however, while central to the explanation of timing, do not explain the form into which a system reconfigured itself. As paleontologists and others realize, environmental shocks are a dime a dozen: some of them have transforming consequences; many of them do not.⁵²

'bailout' policies of Siena (English, 1988). Such policies explain the decline of Sienese bankers, relative to Florentine bankers, in newly emergent international money markets.

⁵²Indeed the effect of war on regimes is wildly variable: sometimes the shock of war increases consolidation of the existing regime (for the Florentine case, see Baron, 1966; more generally, see Tilly, 1975); yet sometimes the shock of war causes regime collapse, even without overt defeat

Metaphorically speaking, how a crystal responds to the blow of a hammer depends upon the fault lines within the crystal, as well as on the direction and force of the blow:

(a) In the case of the patrilineage-to-guild transition, the organizational response of the banking industry to the events just described depended crucially upon the political history of family in Florence. It was no accident that patrilineage--and in particular the father-son bond--declined in partnership importance during the period of 1283 to 1343. The Florentine republic was engaged in a legal, and even physical, war against it.

What does this mean? Numerous things: (1) Large numbers of violent feudally-oriented families were legally declared *magnati* in 1392 by the guild-corporatist republic. This meant that such families were prohibited en bloc from holding major political office.⁵³ (2) In the aftermath of the early 1300's feuds between Black and White Guelfs (made famous by the participation and subsequent exile of Dante), the family towers (urban castles) of

(for the Siennese case, see Caffero, 1998; more generally, see Skocpol, 1979).

⁵³While particular remissions were granted to individual families throughout 1292-1434, this legal exclusion lasted as a category until the Medici abolished it in 1434. Over time, one serious consequence of exclusion was the splintering of magnate patrilineages, as ambitious branches, more interested in cooperating with the guild and *popolani* regimes, separated themselves from their parent magnate lines (Klapisch, 1988). This splintering eventually was so substantial that by 1434 the remaining magnates hardly represented a threat anymore.

the losing White Guelfs were knocked down, and their urban family estates were expropriated, thus repeating the fate of the Ghibellines a few decades before. (3) Laws of so-called emancipation were passed, which gave the father and son for the first time the right voluntarily to appear before the Mercanzia court to declare economic divorce (Kuehn, 1982). That is, fathers could choose publically to renounce (before the fact) legal obligation for the debts of their sons, and vice versa. This of course was a direct assault upon the inner legal logic of family banks.

This multi-faceted assault on patrilineage is paradoxical from the perspective of *popolani* families. Over time, the assault did achieve its titular objective of harming the family-organizational foundation of the magnates, those bitterly sworn enemies of guild corporatism. But *popolani* and *magnati* were identical in family organization.⁵⁴ Hence the *popolani* assault on patrilineage also hurt the organizational foundation of themselves, the main beneficiaries of guild corporatism.⁵⁵

The resolution of the paradox is that the *popolani*, unlike

⁵⁴Indeed they were heavily intermarried as well.

⁵⁵*Popolani*, after all, is defined as “those families first admitted to the Priorate between 1283 and 1342.” They were, in other words, the ruling elite of the guild corporatism regime.

the *magnati*, had guilds as alternative organizational bases of political power. Hence, their control over the state could be preserved as long as *popolani* families effectively shifted from patrilineage to guilds as the organizational foundation for their control. Strengthening the patrilineage side of themselves, conversely, would have mobilized, not demobilized, their opponents. I hypothesize, but have not yet proved, that this instrumental reasoning about political design was self-conscious on the part of the *popolani*.

This is an analysis of politics. How was this politically based patrilineage-to-guild organizational shift transposed into the domain of economics?

The answer is the early 1300s financial crisis, discussed above. In response to this crisis, with the short-term goal of calling in outstanding credits to help them weather the Europe-wide economic storm (English, 1988), Florentine international merchant-bankers used the newly politicized guild framework to strengthen their control over the domestic economy of Florence. This increased economic control had at least two facets: (a) In 1308, the Mercanzia commercial court was established, with the twin economic-cum-political objectives of collecting 'delinquent' debts and of coordinating internationalist control over the five major domestic guilds (Astorri, 1998). And (b) the Arte del

Cambio banking guild itself was used to squeeze lower-level 'free entry' money-changers out of the industry (Najemy, 1972). Partly due to economic bankruptcies, and partly due to this political squeeze, the number of active Arte del Cambio bankers shrunk drastically from 313 'bankers' in 1300 to 117 bankers in 1340, even before the well known (but more temporary in its effects) Bardi bank crisis of 1342.

Through this roughly thirty-year sequence, political expediency became transformed into economic identity: *popolani* merchant-bankers shed their social identity as fathers, and became guild masters, both in their economic and in their political organizations.⁵⁶

(b) Organizational speaking, the core issue in the 1378 *Ciampi* transition, I would argue, was how the term *popolani* became transformed from the mere attributional category it was in the guild-corporatist regime into the generative logic it became in the Albizzi civic-republican regime. On the political side, this transformation meant that an individualizing ideology of state service replaced a collectivist ideology of corporate rights (Najemy, 1982). On the economic side, it meant that

⁵⁶ In this article, I am not really analyzing what happened to family organization in domains outside of politics and economics. There are complicated things to say on this issue, some of which contradict the 'decline of patrilineage' thesis supported here. See for example Cohn (1988,

partnerships were constructed into systems on the logics of *parentado* (intermarriage) and *amicizia* (friendship).

These linked transformations are one of, if not the, major steps along the broader road from medieval to Renaissance. Radically innovative as they were, however, I will argue that they can be understood as the path-dependent reworking of the guild-corporatist republic by the *Ciampi* revolt. The 'exogenous' triggering events of this revolt were alluded to above. But a deeper understanding of the reworking comes through following the political process through which guild corporatism exploded.

It is by now established that the *Ciampi* revolt of the workers was not, in ideology at least, a Marxist economic-class revolt as an earlier generation of scholars had held. Rather it was, in inspiration at least, a moderate demand by *sottoposti* woolworkers to create their own guilds (Brucker, 1968). Economic conditions in the wool industry imparted an urgency to their request, but the request itself was for citizenship, not wages.

Wool-industry conditions notwithstanding, the workers' revolt did not come out of the blue. Parte Guelfa persecutions of new men, themselves fueled by festering magnate exclusions of the past, had polarized the minor guilds into radicalized defense of

1992), who has found that percentage of inheritance passing down through family increased, not decreased, during the Trecento.

the guild-corporatist order. In an escalating spiral, reactionary persecution of new men as 'Ghibellines' begat radical proscription of more conservatives as 'magnates' (Brucker, 1962). The governing major-guilds were shredded by this cross-pressure, since the economic and marriage interests of elite guildsmen conflicted. In such volatile circumstances, elite demagogues or heroes (depending on your point of view), like Salvestro d'Alamanno de' Medici and others, arose to fight for the *popolo minuto* and against the Guelf pope. Interlinked foreign and civil wars became at some point unstoppable.

The *Ciompi* wool workers themselves did not exactly come into this picture at the behest of the minor-guild alliance. But the times were extremely propitious for the expression of citizenship rights for little people (*popolo minuto*), who could help tip the volatile balance. [It certainly helped also that many of these muscular wool workers were ex-soldiers.] Wool workers poured into the streets and defeated *magnati* and *popolani* supporters of the Parte Guelfa in pitched battles, and started to burn many of their houses.⁵⁷ What started as a corporatist demand for guild citizenship escalated behaviorally into a true economic-class (that is, workers') revolt, even without the self-consciousness

⁵⁷Of course such tactics were part of the repertoire of the *popolani* themselves. They were not

of *sottoposti* and *popolo minuti* as 'workers'. Large numbers of the economic elite fled the city in fear of their lives, to their country villas or to their overseas merchant-banking establishments. The teetering wool industry went from bad to collapse; essentially there were no employers left in the city.

The organizational consequences, for the conservatives, of crushing this revolt become obvious once one understands the nature of the challenge. Conservatives were remolded into economic-cum-social class in complement to the economic-cum-class challenge of the *Ciampi* from below.

Old *magnati-popolani* distinctions were somewhat effaced, although never again through the mechanism of Guelfism. The gap between major and minor guilds, already present in the previous regime, intensified.

More important than either of these two re-workings of old categories, the transforming effects on identities of major guildsmen themselves were profound. Guild distinctions between various types of elite merchants were virtually eradicated: in the short run through their bonding experience of flight and counter-coup, in the longer run through their joint agreement, expressed through balie, to emasculate the guilds. Victorious elites understood that the guilds had opened the door to class

used, however, to seeing such methods used against them, especially by the likes of the *Ciampi*.

warfare, which they vowed never to let happen again. So they eliminated guilds as the foundation to the Florentine constitution, taking over the appointment of guild consular leadership, and demoting guilds to little more than social clubs.⁵⁸

Cross-guild political cooperation in electoral reform, through class-based elite networks of *parentado* and *amicizia*, thus preceded (but only by a few years) the analogous cross-industry cooperation of different economic elites in partnership systems. This co-evolution between states and markets is not surprising once one realizes that these two organizational systems were constructed essentially by the same people,⁵⁹ as they mobilized their *parentado* and *amicizia* networks in different domains. It is this wending of biography across sectors, I have argued above, both that establishes protocols-of-communication in systems, and that frames the identity-behind-the-role in individuals.

Conclusion

⁵⁸See Rubinstein (1981), Najemy (1982), and Franceschi (1993b) for institutional details. Fortunately for my data, guilds continued to register matriculation and partnerships; however, they did little else. I have discussed the marriage side of this transformation of *popolani* into oligarchy in Padgett and Ansell (1993).

⁵⁹I only add the qualifier “essentially” because of the well-known tendency for brothers to

What is life? In biological chemistry, life is a tangled web of self-regulating loops of chemical reactions, which reproduce themselves through time (Eigen, 1992; Buss, 1987; Fontana and Buss, 1994; Padgett, 1997; Jain and Krishna, 1998). The history of life is thus a path-dependent series of bifurcating networks, each step of which must lock in to stabilize itself for the next step to be possible (Goodwin, 1994). Neutral drift at the level of individual molecules is consistent with discontinuous tipping at the level of autocatalytic chemical networks (Fontana and Schuster, 1998). Viewed from a distance, evolution is a growing bush of co-adaptations, refunctionalities and dead ends, with selective pruning but no inherent teleology (Gould, 1980, 1989).

The contribution of the line of research in this article to evolutionary theory is to emphasize the multiple-network character of these bifurcations. Human beings, just like chemical molecules, participate in multiple loops of self-regulating activity. As such, perturbations in one loop may rebound, for good or ill, into other loops. In addition to this point about developmental regulation, I argue that the possible trajectories of evolution of one social network (such as economic partnerships) are shaped by the structure of surrounding social networks in which that one network is embedded. Burgeoning

construct their little divisions of labor—one politician, one businessman (Goldthwaite, 1968).

pressures in one network, moreover, may urge other networks down one trajectory of possibility or another.

Because of such network interaction effects, the abstract history of financial capitalism should not be reified away from the concrete particulars of Florentine or of any other history. Naturally, diffusion across settings also occurs. But explaining diffusion is different from explaining invention. In the social sciences, we have plenty of models for the former, precious few for the latter.

In this paper, I have used my empirical research on Florentine banking as a platform from which to sketch a more general theory or interpretation of the genesis of organizational morphology. At the level of organizational genetics, this involves career matching. At the level of organizational development, this involves bankers' logics-of-identity, which are regulated by the biographical political access of elites, and which unfold through bankers' social networks to spawn banks. At the level of organizational speciation, this involves the realignment of cross-domain bankers' identities, which function at the system level as dialogues or protocols through which politics and markets communicate with each other.

Whether or not this framework is exactly what Stinchcombe had in mind in his 1965 inspiration is hard to say. But this

article is one attempt to follow the markers of Stinchcombe's path-blazing but fading trail.

Bibliography

- Astorri, Antonella. 1998. La Mercanzia a Firenze nella Prima Meta del Trecento. Florence: Leo. S. Olschki Editore.
- Baron, Hans. 1966. The Crisis of the Early Italian Renaissance. Princeton, N.J.: Princeton University Press.
- Baxendale, Susannah Foster. 1991. 'Exile in Practice: The Alberti Family in and out of Florence,' Renaissance Quarterly 44:720-756.
- Breiger, Ronald L. 1974. 'The Duality of Persons and Groups,' Social Forces 53:181-190.
- Brown, Alison. 1992. "Lorenzo, the Monte and the Seventeen Reformers," in A. Brown, The Medici in Florence: The exercise and language of power. Firenze: Leo S. Olschki editore.
- Brucker, Gene. 1962. Florentine Politics and Society, 1343-1378. Princeton, N.J.: Princeton University Press.
- Brucker, Gene. 1967. Two Memoirs of Renaissance Florence: The Diaries of Buonaccorso Pitti and Gregorio Dati. New York: Harper.
- Brucker, Gene. 1969. Renaissance Florence. Berkeley, Cal.: University of California Press.
- Brucker, Gene. 1968. 'The Ciompi Revolution,' in Nicolai Rubinstein (ed.), Florentine Studies: Politics and Society

- in Renaissance Florence. Evanston, Ill.: Northwestern University Press.
- Brucker, Gene. 1977. The Civic World of Early Renaissance Florence. Princeton, N.J.: Princeton University Press.
- Burckhardt, Jacob. 1954 [1860]. The Civilization of the Renaissance in Italy. New York: The Modern Library.
- Buss, Leo W. 1987. The Evolution of Individuality. Princeton, N.J.: Princeton University Press.
- Caffero, William. 1998. Mercenary Companies and the decline of Siena. Baltimore, Md.: The Johns Hopkins University Press.
- Carruthers, Bruce G. 1996. City of Capital: Politics and Markets in the English Financial Revolution. Princeton, N.J.: Princeton University Press.
- Cohn, Samuel K. 1988. Death and Property in Siena, 1205-1800: Strategies for the Afterlife. Baltimore: The Johns Hopkins Press.
- Cohn, Samuel K. 1992. The Cult of Remembrance and the Black Death. Baltimore: The Johns Hopkins Press.
- De Roover, Raymond. 1958. 'The Story of the Alberti Company of Florence, 1302-1348, as Revealed in its Account Books,' Business History Review. 32:14-59.
- De Roover, Raymond. 1966. The Rise and Decline of the Medici Bank, 1397-1494. New York: Norton.

- Douglas, Mary. 1986. How Institutions Think. Syracuse, N.Y.: Syracuse University Press.
- Duranti, Alessandro and Charles Goodwin. 1992. Rethinking Context: Language as an interactive phenomenon. Cambridge: Cambridge University Press.
- Eckstein, Nicholas A. 1995. The District of the Green Dragon: Neighborhood Life and Social Change in Renaissance Florence. Firenze: Leo S. Olschki editore.
- Eigen, Manfred. 1992. Steps toward Life: A Perspective on Evolution. Oxford: Oxford University Press.
- Emirbayer, Mustafa and Jeff Goodwin. 1994. 'Network Analysis, Culture, and the problem of Agency,' American Journal of Sociology 99:1411-1454.
- English, Edward D. 1988. Enterprise and Liability in Sienese Banking, 1230-1350. The Medieval Academy of America.
- Fontana, Walter and Leo W. Buss. 1994. "'The arrival of the fittest': Toward a theory of biological organization," Bulletin of Mathematical Biology 56:1-64.
- Fontana, Walter and Peter Schuster. 1998. "Continuity in evolution: on the nature of transitions," Science 280:1451-54.
- Franceschi, Franco. 1993a. Oltre il "Tumulto": I laboratori fiorentini dell'Arte della Lana fra Tre e Quattrocento.

Firenze: Leo S. Olschki editore.

Franceschi, Franco. 1993b. 'Intervento del potere e ruolo delle Arti nel governo dell'economia fiorentina del Trecento e del primo Quattrocento. Linee generali,' Archivio Storico Italiano. 151:863-909.

Fubbini, Riccardo. 1996. "Prestito ebraico e Monte di Pieta a Firenze (1471-1473)," in R. Fubbini, Quattrocento fiorentino: Politica, diplomazia, cultura. Pisa: Pacine editore.

Goffman, Erving. 1974. Frame Analysis: An Essay on the Organization of Experience. Boston: Northeastern University Press.

Goldthwaite, Richard A. 1968. Private Wealth in Renaissance Florence: A Study of Four Families. Princeton, N.J.: Princeton University Press.

Goldthwaite, Richard A. 1985. "Local banking in Renaissance Florence," The Journal of European Economic History 14: 5-55.

Goldthwaite, Richard A. 1987. "The Medici bank and the world of Florentine Capitalism," Past and Present 114:3-31.

Goldthwaite, Richard A. 1983. "Organizzazione economica e struttura familiare," in I ceti dirigenti nella Toscana tardo comunale. Firenze: Francesco Papafava editore.

- Goldthwaite, Richard A. 1993. Wealth and the Demand for Art in Italy, 1300-1600. Baltimore, Md.: Johns Hopkins University Press.
- Goodwin, Brian. 1994. How the Leopard Changed its Spots: The Evolution of Complexity. New York: Simon and Schuster.
- Gould, Steven J. 1980. The Panda's Thumb. New York: Norton.
- Gould, Steven J. 1989. Wonderful Life: The Burgess Shale and the Nature of History. New York: Norton.
- Gramsci, Antonio. 1971. Selections from the Prison Notebooks, edited and translated by Quintin Hoare and Geoffrey Nowell Smith. New York: International Publishers.
- Granovetter, Mark. 1985. "Economic action and social structure: The problem of embeddedness," American Journal of Sociology 91:481-510.
- Gregory, Heather. 1997. Selected Letters of Alessandra Strozzi. Berkeley, Cal.: University of California Press.
- Greif, Avner. 1994. 'On the Political Foundations of the Late Medieval Commercial Revolution: Genoa during the Twelfth and Thirteenth Centuries,' Journal of Economic History 54:271-287.
- Hoshino, Hidetoshi. 1980. L'Arte della Lana in Firenze nel Basso Medioevo. Firenze: Leo S. Olschki editore.
- Housley, Norman. 1982. The Italian Crusades. Oxford: Clarendon

Press.

Jain, Sanjay and S. Krishna. 1998. 'Autocatalytic Sets and the Growth of Complexity in an Evolutionary Model,' Physical Review Letters 81:5684-87.

Janowitz, Morris. 1991. On Social Organization and Social Control. Chicago: University of Chicago Press.

Jenkins, A.D. Fraser. 1970. 'Cosimo de Medici's Patronage of Architecture and the Theory of Magnificence,' Journal of the Warburg and Courtauld Institutes. 33:162-170.

Kaeuper, Richard W. 1973. Bankers to the Crown: The Ricciardi of Lucca and Edward I. Princeton, N.J.: Princeton University Press.

Kauffman, Stuart A. 1993. The Origins of Order. New York: Oxford University Press.

Kent, F.W. 1977. Household and Lineage in Renaissance Florence. Princeton, N.J.: Princeton University Press.

Klapisch-Zuber, Christiane. 1988. 'Ruptures de parente et changements d'identite chez les magnats Florentins du XIVE siecle,' Annals ESC 43:1205-1240.

Klapisch-Zuber, Christiane. 1985. Women, Family, and Ritual in Renaissance Italy. Chicago: University of Chicago Press.

Kuehn, Thomas. 1982. Emancipation in Late Medieval Florence. New Brunswick, N.J.: Rutgers University Press.

- Lansing, Carol. 1991. The Florentine Magnates: Lineage and Faction in a Medieval Commune. Princeton, N.J.: Princeton University Press.
- LaSorsa, Saverio. 1904. L'organizzazione dei cambiatori fiorentini. Cerignola: Tip. edit. dello 'scienza e diletto'.
- Leifer, Eric. 1988. 'Interaction Preludes to Role Setting: Exploring Local Action,' American Sociological Review 53:865-878.
- Lopez, Robert S. 1976. The Commercial Revolution of the Middle Ages, 950-1350. Cambridge: Cambridge University Press.
- March, James C. and James G. March. 1977. 'Almost Random Careers: The Wisconsin School Superintendency, 1940-1972,' Administrative Science Quarterly 22:377-409.
- Marks, Louis F. 1960. "The financial oligarchy in Florence under Lorenzo," in E.F. Jacob (ed.), Italian Renaissance Studies. London: Faber and Faber.
- May, Robert M. 1973. Stability and Complexity in Model Ecosystems. Princeton, N.J.: Princeton University Press.
- McLean, Paul D. 1996. Patronage and Political Culture: Strategies of Self-Presentation, Roles, and Identity in Renaissance Florence. Ph.D. dissertation, Department of Political Science, University of Chicago.
- McLean, Paul D. and John F. Padgett. 1997. 'Was Florence a

- perfectly competitive market? Transactional evidence from the Renaissance,' Theory and Society 26:209-244.
- Melis, Federigo. 1962. Aspetti della vita economica medievale. Studi nell'Archivio Datini di Prato. Siena: Monte del Paschi di Siena.
- Meyer, John and W. Richard Scott. 1983. Organizational Environments: Ritual and Rationality. Beverly Hills, Cal.: Sage.
- Mischel, Walter. 1990. 'Personality Dispositions Revisited and Revised: A View after Three Decades.' Handbook of Personality Theory and Research, edited by L. Pervin. New York: Guilford Press.
- Molho, Anthony. 1979. 'Cosimo de Medici: Pater Patriae or Padrino?' Stanford Italian Review. 1:5-33.
- Molho, Anthony. 1994. Marriage Alliance in Late Medieval Florence. Cambridge, Mass.: Harvard University Press.
- Najemy, John M. 1972. The Guilds in Florentine Politics, 1292-1394. Unpublished dissertation, Harvard University.
- Najemy, John M. 1981. "'Audiant omnes artes': Corporate origins of the Ciompi revolution," in Istituto nazionale di studi sul Rinascimento, Il Tumulto dei Ciompi. Firenze: Leo S. Olschki editore.
- Najemy, John M. 1982. Corporatism and Consensus in Florentine

- Electoral Politics, 1280-1400. Chapel Hill, N.C.: University of North Carolina Press.
- Najemy, John M. 1991. 'The Dialogue of Power in Florentine Politics,' in City-States in Classical Antiquity and Medieval Italy, edited by Anthony Molho, Kurt Raaflaub, and Julia Emlen. Ann Arbor, Mich.: University of Michigan Press.
- Newman, Stuart A. 1994. "Generic physical mechanisms of tissue morphogenesis: A common basis for development and evolution," Journal of Evolutionary Biology 7:467-488.
- Padgett, John F. 1990. "Mobility as control: Congressmen through committees," in Ronald L. Breiger (ed.), Social Mobility and Social Structure. Cambridge: Cambridge University Press.
- Padgett, John F. and Christopher K. Ansell. 1993. "Robust action and the rise of the Medici, 1400-1434," American Journal of Sociology 98:1259-1319.
- Padgett, John F. 1997. "The emergence of simple ecologies of skill: A hypercycle approach to economic organization," in Brian Arthur et al. (eds.), The Economy as an Evolving Complex System II, SFI Studies in the Sciences of Complexity: Addison-Wesley.
- Powell, Walter W. and Paul J. DiMaggio. 1991. The New Institutionalism in Organizational Analysis. Chicago: The University of Chicago Press.

- Prigogine, Ilya and Isabella Stengers. 1984. Order out of Chaos. New York: Bantam.
- Rubinstein, Nicolai. 1966. The Government of Florence under the Medici (1434 to 1494). Oxford: Oxford University Press.
- Rubinstein, Nicolai. 1981. 'Il regime politico di Firenze dopo il Tumulto dei Ciompi,' in Istituto Nazionale di Studi sul Rinascimento, Il Tumulto dei Ciompi: Un momento di storia Fiorentina ed Europea. Florence: Leo S. Olschki editore.
- Sapori, Arnando. 1926. La crisi delle compagnie mercantili dei Bardi e dei Peruzzi. Florence: Leo S. Olschki Editore.
- Schevill, 1961. History of Florence. New York: Frederick Unger Publishing.
- Schweizer, Thomas and Douglas White (eds.). 1998. Kinship, Networks, and Exchange (Structural Analysis in the Social Sciences). Cambridge: Cambridge University Press.
- Sewell, William Jr. 1980. Work and Revolution in France: The Language of Labor from the Old Regime to 1848. Cambridge: Cambridge University Press.
- Skocpol, Theda. 1976. 'Old Regime Legacies and Communist Revolutions in Russia and China,' Social Forces 55: 284-315.
- Skocpol, Theda. 1979. States and Social Revolutions. Cambridge: Cambridge University Press.
- Stark, David and Laszlo Bruszt. 1998. Postsocialist Pathways:

- Transforming Politics and Property in East Central Europe.
Cambridge: Cambridge University Press.
- Stinchcombe, Arthur. 1965. "Social structure and organizations,"
in James G. March (ed.), Handbook of Organizations. New
York: Rand McNally.
- Tilly, Charles. 1975. The Formation of National States in Western
Europe. Princeton, N.J.: Princeton University Press.
- Tognetti, Sergio. 1999. Il Banco Cambini: Affari e mercati di una
compagnia mercantile-bancaria nella Firenze del XV secolo.
Florence: Leo. S. Olschki Editore.
- Trexler, Richard. 1974. The Spiritual Power: Republican Florence
under Interdict. Leiden: Brill.
- Villani, Giovanni. 1844-45 [1350-?]. Cronica di Giovanni Villani,
edited by F. Dragomanni. Florence:
- Weissman, Ronald. 1989. 'The Importance of being Ambiguous:
Social Relations, Individualism, and Identity in Renaissance
Florence.' Pp. 269-280 in Urban Life in the Renaissance,
edited by Susan Zimmerman and Ronald Weissman. Dover, Del.:
University of Delaware Press.
- White, Harrison C. 1992. Identity and Control: A Structural
Theory of Social Action. Princeton, N.J.: Princeton
University Press

Figure 1b. Typical Life Course for Family Firms: Brother-Brother mode

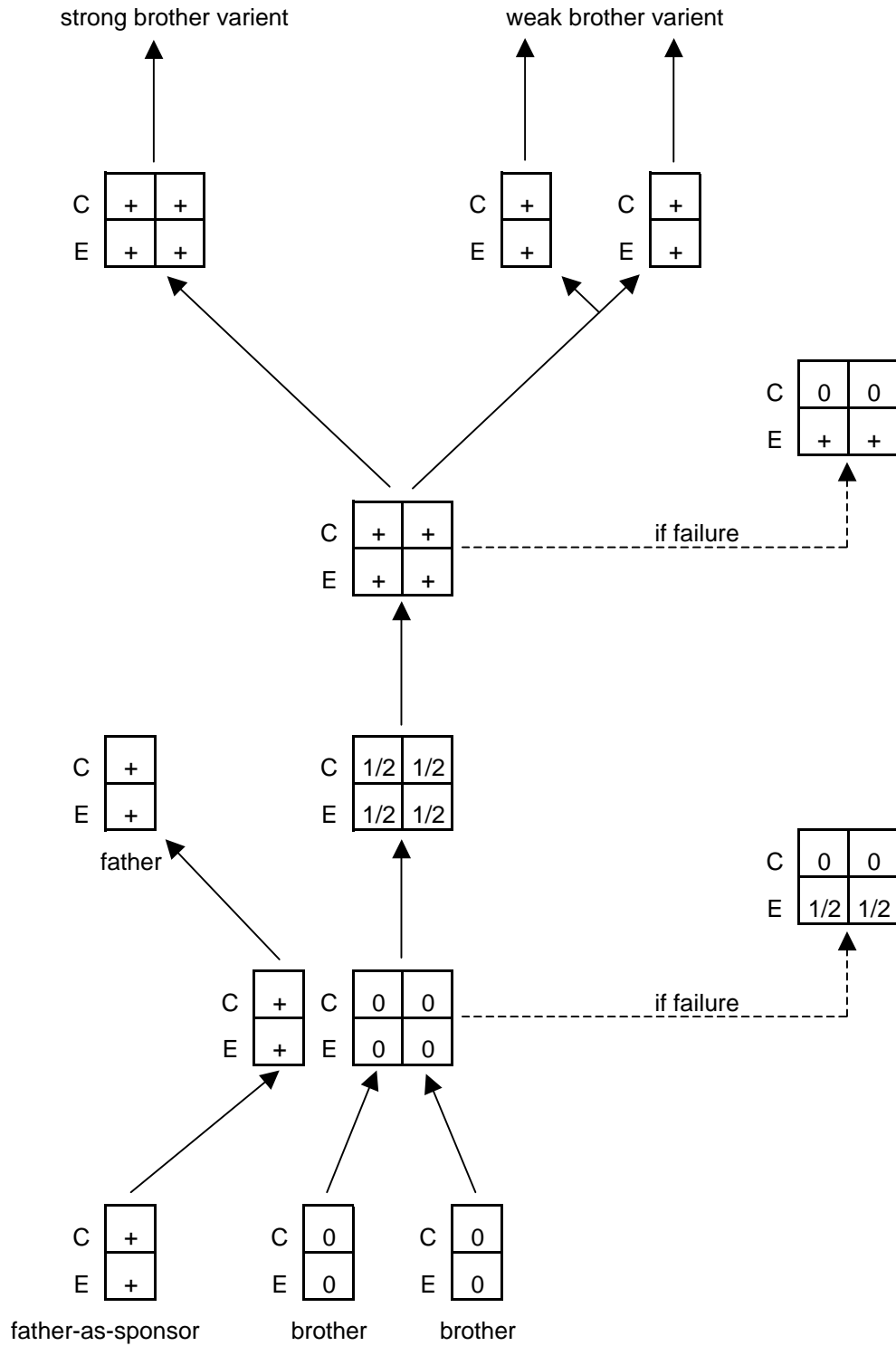

Figure 2. Typical Life Course for Guild Firms

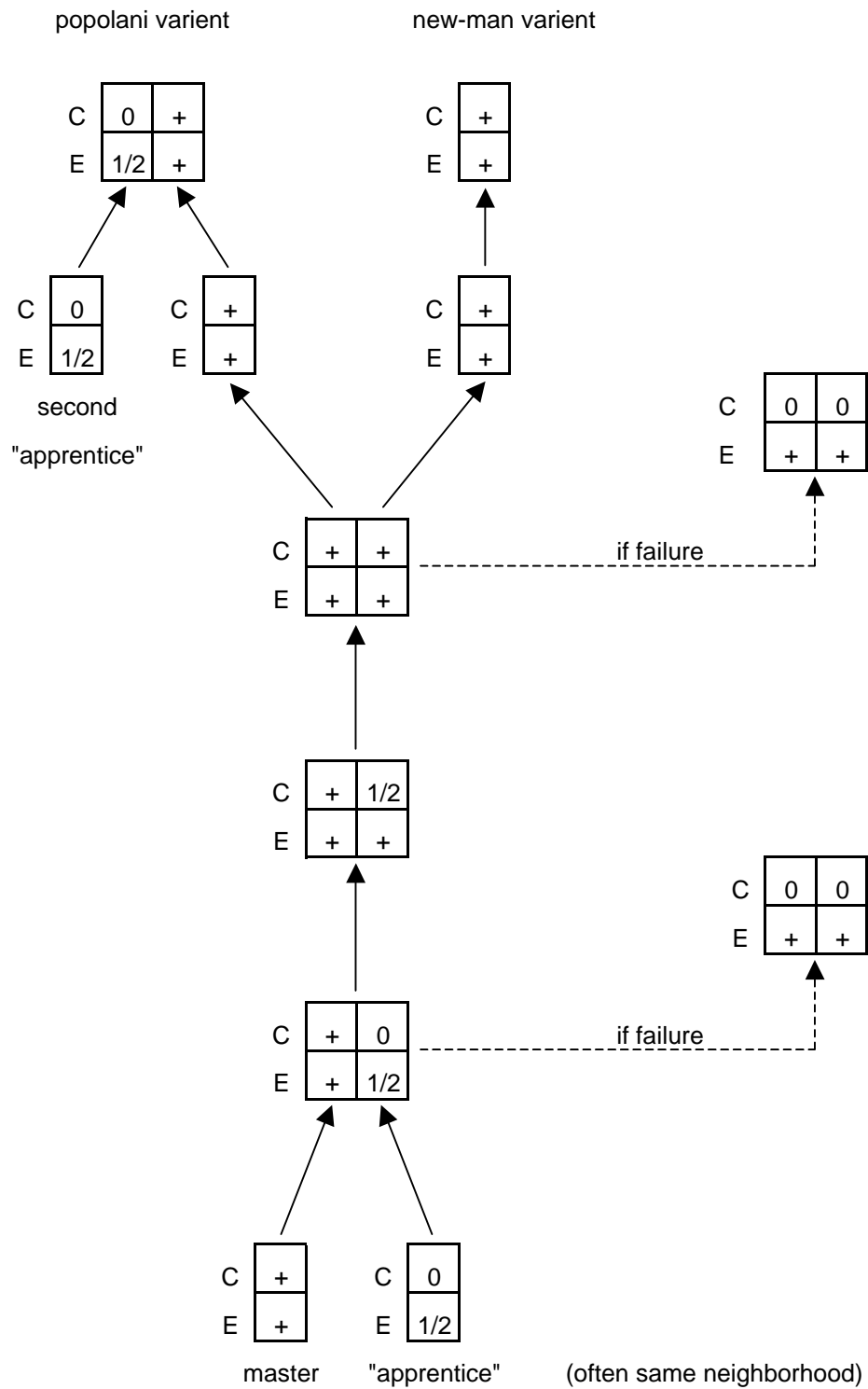

Figure 3a. Typical Life Course for Popolani Firms: Inter-marriage mode

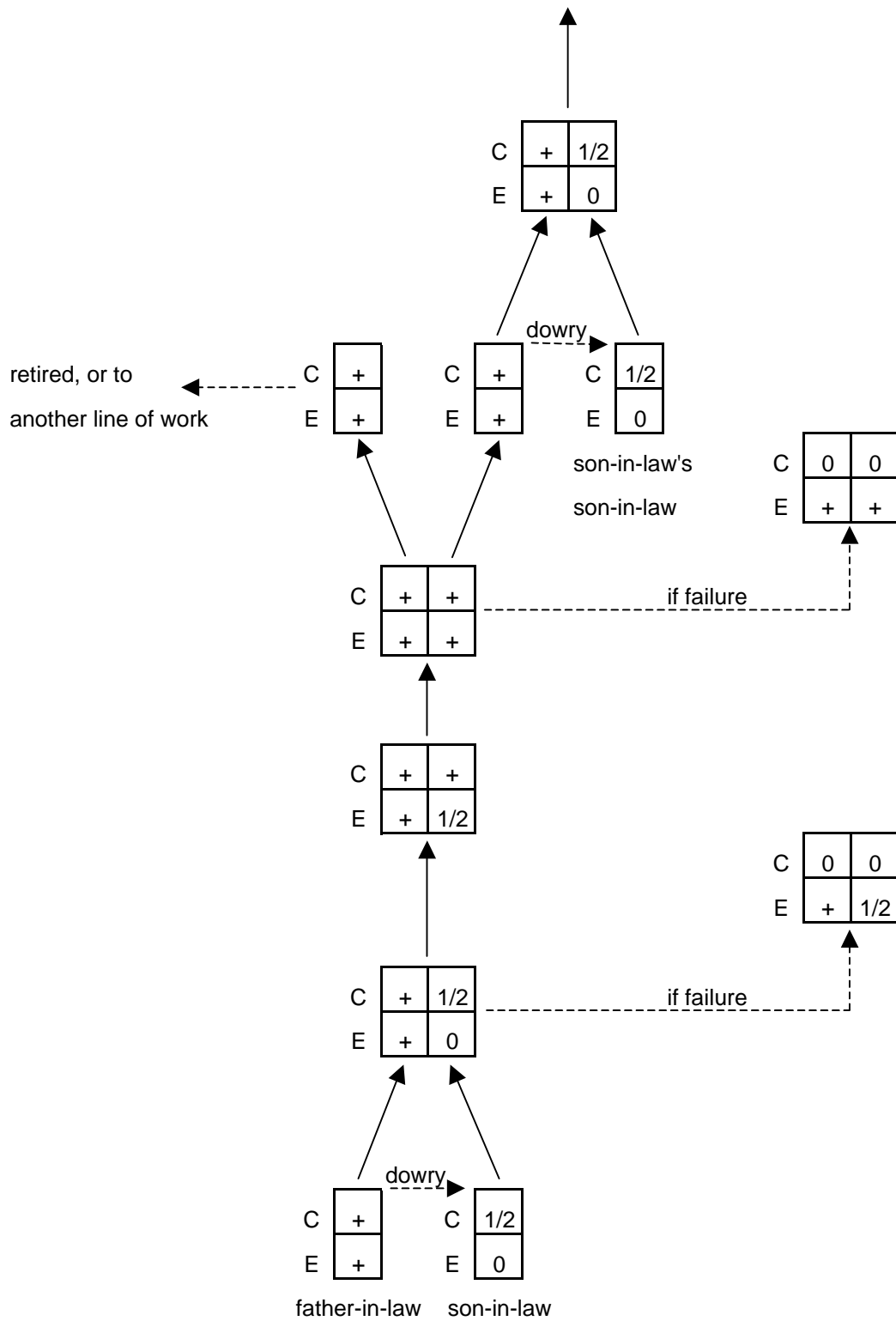

Figure 3b. Typical Life Course for Popolani Firms: Amicizia mode

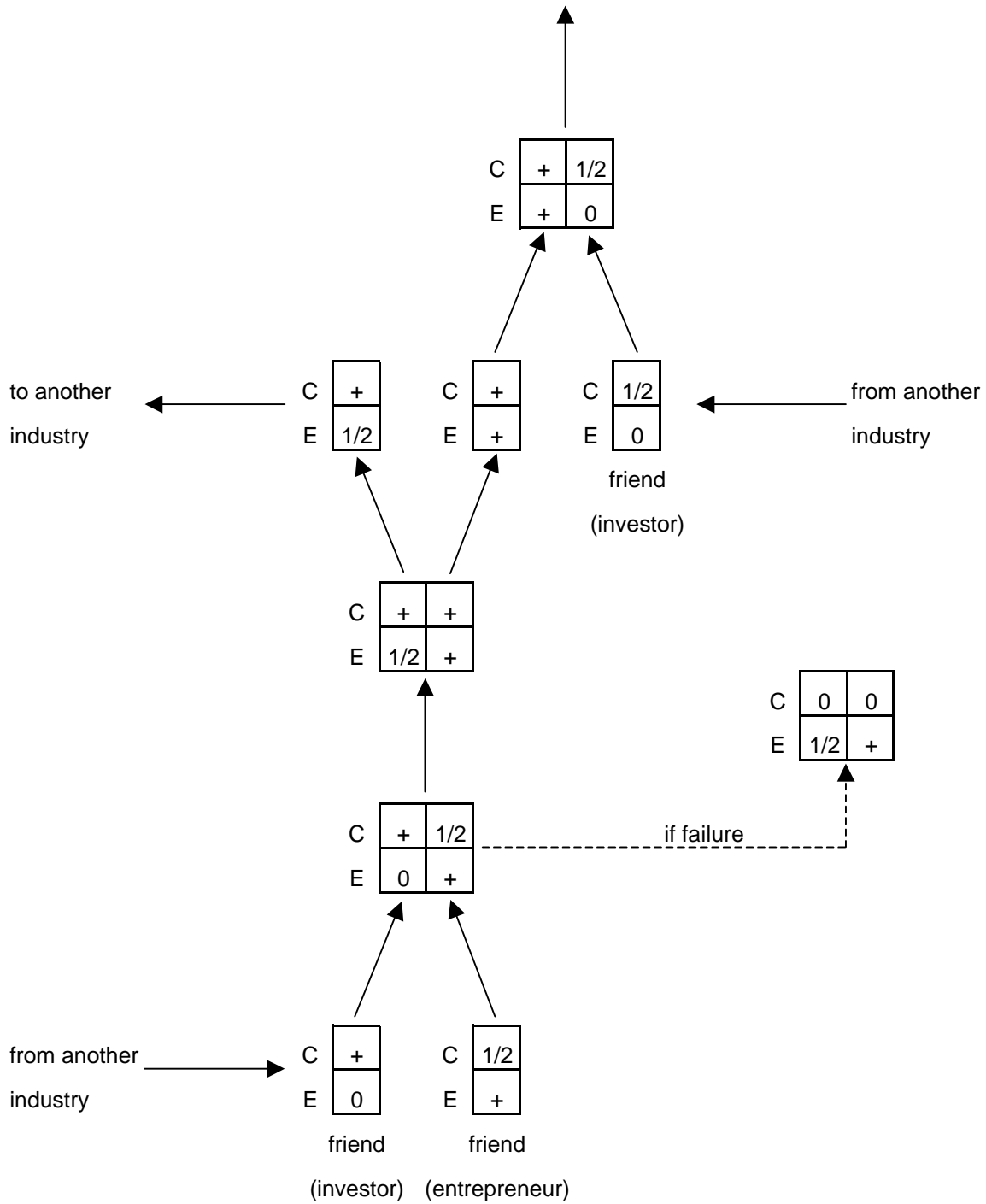

Figure 4. Summary of Alternate Vertical Partnership Relations
(C & E profiles at beginning of relation)

C	+	0
E	0	+

extreme patronage
(Medici period)

C	+	1/2
E	0	+

popolani amicizia
(popolani "system")

C	+	0
E	1/2	+

new man amicizia
(Datini "system")

C	+	+
E	+	0

kindred/parentado
(same generation)

C	+	0
E	+	+

guild master-master

C	+	1/2
E	+	0

kindred/parentado
(cross generation)

C	+	1/2
E	+	0

guild master-apprentice

C	+	0
E	+	0

father-son

N.B.: Each of these modes has variants in how they unfold, depending upon how long the relation is expected to last.