

ATTRIBUTIVE COMPARATIVE DELETION*

ABSTRACT. Comparatives are among the most extensively investigated constructions in generative grammar, yet comparatives involving attributive adjectives have received a relatively small amount of attention. This paper investigates a complex array of facts in this domain that shows that attributive comparatives, unlike other comparatives, are well-formed only if some type of ellipsis operation applies within the comparative clause. Incorporating data from English, Polish, Czech, Greek, and Bulgarian, we argue that these facts support two important conclusions. First, violations of Ross's Left Branch Condition that involve attributive modifiers should not be accounted for in terms of constraints on LF representations (such as the Empty Category Principle), but rather in terms of the principle of Full Interpretation at the PF interface. Second, ellipsis must be analyzed as deletion of syntactic material from the phonological representation. In addition, we present new evidence from pseudogapping constructions that favors an articulated syntax of attributive modification in which certain types of attributive modifiers may occur outside DP.

1. INTRODUCTION

1.1. *Comparative Deletion*

Comparative deletion (CD) is the term introduced by Bresnan (1973, 1975) to describe constructions in which an adjectival, adverbial, or nominal constituent is eliminated from the surface representation of the complement of *than* or *as* (henceforth the comparative clause) in sentences such as (1a–c).

* We have profited greatly from discussion of this material with Sandy Chung, Norbert Corver, Dan Hardt, John Frampton, Anastasia Giannakidou, Jim McCloskey, Eric Potsdam, and Chris Wilder. We are also very thankful to the native speakers to whom we owe our non-English data for their patience in judging numerous difficult examples: Dorothea Mokrosinska and Rami Nair (Polish), Anna Pilátová (Czech), Lena Goretskaya and Sergey Avrutin (Russian), Anastasia Giannakidou and Yoryia Agouraki (Greek), and Branimir Boguraev (Bulgarian). Thanks also to the many English speakers who provided judgments. Earlier versions of this paper have been presented at CSSP2 (Paris), ZAS (Berlin), MIT, Northwestern University, UC-Santa Cruz and USC; we are grateful to those audiences for their many valuable comments and suggestions. Finally, we would like to express our thanks to the *NLLT* reviewers, whose comments led to many important improvements in the final version of the paper.



- (1)a. Pico's novel was more interesting than Brio thought it would be ____.
- b. Dennis wrestles less energetically than he rebounds ____.
- c. Zizou didn't score as many goals as we thought he would score ____.

Standard analyses of CD constructions hypothesize that they are related to representations that contain constituents identical to the comparative terms in the main clause, the only difference being that the comparative morpheme is replaced by a variable that ranges over degrees, as in (2a–c).¹

- (2)a. Pico's novel was more interesting than Brio thought it would be [**x-much interesting**]
- b. Dennis wrestles less energetically than he rebounds [**x-much energetically**]
- c. Zizou didn't score as many goals as we thought he would score [**x-many goals**]

In Bresnan's original analysis, an unbounded deletion operation eliminates the boldfaced material in (2a–c) under identity with material in the main clause (Bresnan 1973, 1975, Borsley 1981; see also Lees 1961, Chomsky 1965). Later work, building on observations by Ross (1967) and Chomsky (1977) that comparatives have properties characteristic of *wh*-constructions, reformulated Bresnan's analysis in terms of *wh*-movement of a degree term plus some mechanism for deleting or recovering the content of the remaining lexical material (see, e.g., Klein 1980, von Stechow 1984, Heim 1985, Larson 1988, Moltmann 1992, Hazout 1995, Izvorski 1995, Lerner and Pinkal 1995, Rullmann 1995, and others; see Hendriks and de Hoop 1998 for an alternative view).²

¹ This assumption is very well-justified semantically, as numerous studies on the interpretation of comparatives have demonstrated (see Kennedy 1999a for an overview). Since our intention in this paper is to investigate the syntactic properties of attributive comparatives, we will not attempt to provide a detailed semantic analysis here. All of our syntactic claims are compatible with standard assumptions about the interpretation of comparatives, however.

² Two sets of facts support the analysis of CD in terms of *wh*-movement. First, CD constructions are sensitive to extraction islands, display crossover effects, and license parasitic gaps (see Ross 1967, Bresnan 1975, Chomsky 1977, and Grimshaw 1987; see Rullmann 1995 for discussion of semantic similarities between comparatives and *wh*-questions).

Differences aside, both analyses share the basic assumption that the ‘missing’ material in the comparative clause of examples like (1a–c) is present at some level of representation. One argument in favor of a deletion approach, articulated in Bresnan (1975), is that it also provides a principled analysis of so-called *comparative subdeletion* constructions, exemplified by (3)–(4), which differ from CD constructions in that only a degree term is missing.

- (3) By actually refuting his own early self, Wittgenstein was as unusual as Frege was ___ noble when confronting – not to say applauding – Russell’s objections. (*Times Literary Supplement*, 6.26.1998)
- (4) Michael Jordan has more scoring titles than Dennis Rodman has ___ tattoos. (*Chicago Tribune*, 7.17.1998)

An analysis in which subdeletion constructions involve movement of a degree term out of AP (a characteristic of most movement accounts; see Grimshaw 1987 and Corver 1993 for discussion) conflicts with the fact that movement of overt expressions from the same syntactic position is impossible in English:

- (5) *How (much) was Wittgenstein unusual?
- (6) *How many does Dennis Rodman have tattoos?

(5)–(6) violate Ross’s (1967) *Left Branch Condition* (see also Corver 1990), yet these examples manifest exactly the type of movement hypothesized to occur in (3) and (4) (but see Izvorski 1995 for a movement analysis that avoids this problem). However, if the Left Branch Condition is a constraint on movement, but not unbounded deletion (a position that Bresnan provides extensive arguments for; see in particular Bresnan 1975, pp. 67–68), then both the well-formedness of subdeletion and the unacceptability of examples like (5)–(6) can be accommodated.

The deletion approach to CD receives a serious challenge from a set of facts first discussed by Pinkham (1985), however. Pinkham observes that in comparatives involving attributive adjectives, CD *cannot* target just the

Second, many languages (including Afrikaans, Bulgarian, Dutch, Greek, Hindi, Polish, and some varieties of English) permit an overt *wh*-word in the comparative clause; see Hankamer 1979, den Besten 1978, Borsley 1981, Rudin 1984a,b, and Izvorski 1995.

corresponding AP in the comparative clause, as shown by (7a–d) (see also Pilch 1965).

- (7)a. *Pico wrote a more interesting novel than Brio wrote a ___ play.
- b. *Erik drives a more expensive car than Polly drives a ___ motorcycle.
- c. *Jones produced as successful a film as Smith produced a ___ play.
- d. *The Cubs started a more talented infield than the Sox started an ___ outfield.

The impossibility of deletion of the attributive APs, which are canonical left-branch constituents, provides a direct counterargument to a Bresnan-style unbounded deletion analysis. Since such an analysis is constructed precisely to allow comparative deletion to target left-branch constituents, it incorrectly predicts that examples like (7a–d) should be well-formed.³

On the other hand, the unacceptability of (7a–d) appears at first glance to provide excellent support for a movement analysis of CD (assuming that the problem of subdeletion can be resolved; see Chomsky 1977, p. 123 for a proposal). Two versions of this approach have been proposed in the literature, which differ primarily in their assumptions about the nature of the moved constituent. In the first type of approach (see, e.g., Chomsky 1977, Klein 1980, Larson 1988, and Kennedy 1999a, 1999b), CD is analyzed as movement of a full adjectival constituent; in the second, the moved constituent is a degree term, and the remaining lexical material is deleted or recovered in accord with other principles (see, e.g., Heim 1985 and

³ Bresnan presents the example in (i) as evidence that CD can target left-branch APs (see Bresnan 1975, p. 50, ex. (96)); the naturally occurring example in (ii) makes the same point.

- (i) George is as phony a hatcheck girl as Mildred is a ___ bouncer.
- (ii) Damon is a better lobsterman than he is a ___ cook. (overheard by CK, 7.22.1998)

We agree with Bresnan's judgment on these examples. However, we will provide evidence in Section 5.2 that (i)–(ii) do not counterexemplify Pinkham's generalization about CD in attributive comparatives, but rather fall into the same class as the pseudogapping constructions to be discussed in Section 1.2 below.

Izvorski 1995). (8a–b) illustrate the structures assigned to (7a) by the two approaches, respectively, where the boldface type in (8b) indicates material that is unpronounced in the surface form. (We assume for simplicity that the moved element is phonologically null, rather than a deleted *wh*-phrase, as in Chomsky 1977.)

- (8)a. Pico wrote a more interesting novel than [*Op_i* Brio wrote a *t_i* play]
- b. Pico wrote a more interesting novel than [*Op_i* Brio wrote a [*t_i* **interesting**] play]

Differences aside, both approaches support a straightforward explanation of the unacceptability of (7a–d). As shown by (9a–c), overt movement of either a full AP or a degree term from attributive position is impossible in English, unless the rest of the NP is pied-piped along with it.

- (9)a. *How interesting did Pico write a novel?
- b. *How (much) did Pico write an interesting novel?
- c. How interesting a novel did Pico write?

According to Corver (1990, pp. 318–322), questions like (9a–b) (which, like (5)–(6), violate the Left Branch Condition) are ill-formed because movement of, or out of, an attributive adjectival phrase triggers a violation of the Empty Category Principle (an ECP approach is also proposed in Bowers 1987). Assuming a DP structure in which attributive adjectival phrases are left-adjoined to *N'*, Corver argues that extraction crosses at least one non-L-marked XP, namely NP. He further assumes that NP is not a licit adjunction site, so extraction must cross it directly, yielding the desired ECP violation. (Corver tentatively assumes that the attributive phrase could proceed via SpecDP (cf. Giorgi and Longobardi 1991), so the fact that DP would be a barrier by inheritance plays no role.) If this proposal is correct, and if CD involves the same type of movement as either (9a) or (9b), then the impossibility of attributive CD in (7a–d) can also be explained in terms of an ECP violation.

Although the syntactic parallelism between the comparatives in (7) and the questions in (9a–b) (particularly (9a), a point we will return to below) makes a strong case for a movement analysis of CD, there is clear evidence that an ECP-based explanation of attributive CD cannot be correct. As observed by Pinkham (1985), CD can target an attributive AP just in case

a constituent that contains the attributive position is also eliminated from the surface form. This effect is illustrated by (10a–d), in which the four options in brackets involve a missing DP, VP, CP, and I', respectively.⁴

- (10)a. Pico wrote a more interesting novel than Brio {wrote, did, expected, \emptyset } ____.
- b. Erik drives a more expensive car than Polly {drives, does, said, \emptyset } ____.
- c. Jones produced as successful a film as Smith {produced, did, had hoped, \emptyset } ____.
- d. The Cubs started a more talented infield than the Sox {do, started, think, \emptyset } ____.

The problem presented by these examples for an ECP-based account of attributive CD can be illustrated by considering (10a). Given the assumptions outlined above, (10a) should have either the Logical Form in (11a) or the one in (11b), in which boldface type indicates elided material. (This representation illustrates the case of an elided verb phrase, which we focus on for simplicity; our remarks apply equally to the cases in which other constituents are elided.)

- (11)a. Pico wrote a more interesting novel than [Op_i Brio did **write a t_i novel**]
- b. Pico wrote a more interesting novel than [Op_i Brio did **write a [t_i interesting] novel**]

(11a–b) are structurally identical to (8a–b). It follows that if (8a–b) violate the ECP, as hypothesized above, and if this constraint is enforced (only) at LF (see Chomsky 1995 and related work), then attributive CD should not only be impossible when just an attributive AP is targeted, as in (7a–d), but *attributive CD should be impossible in general*. This is clearly the wrong prediction.⁵

⁴ Whether the missing constituent in the fourth option is I', IP, or some other (maximal) inflectional projection is irrelevant to the current discussion (though we return to this question in Section 5.1). For ease of reference, we will refer to these examples as instances of 'comparative stripping', without committing ourselves to a particular analysis of the category of the missing constituent.

⁵ An anonymous reviewer correctly observes that the facts in (10a–d) are problematic for an ECP-based analysis of the Left Branch Condition only if they actually involve

The conclusion to be drawn from this discussion is that neither the deletion analysis of CD nor an ECP-based movement analysis provides a satisfactory explanation of the facts of attributive comparative deletion: the former overgenerates, predicting that examples like (7a–d) should be acceptable, while the latter undergenerates, ruling out the well-formed cases in (10a–d) along with (7a–d). The basic puzzle is summarized in the descriptive generalization in (12) (the title of which is borrowed from Pinkham 1985, p. 47).

- (12) *When everything goes, anything goes*
 Comparative deletion in attributive comparatives is possible only if a constituent that (properly) contains the targeted AP is also eliminated from the surface representation.

movement of just the attributive modifier or degree term, as in (11a–b). If, however, these constructions involve movement of a larger constituent – in particular, if they involve pied-piping of (at least) DP along with the null operator, followed by deletion (of both the pied-piped material and (optionally) the VP/CP/IP) – then their well-formedness would follow, and the challenge to the ECP account of the Left Branch Condition would be removed. The reviewer therefore asks the important question: is there independent evidence that (10a–d) are derived as illustrated in (11a–b)? In fact, there is such evidence, at least for the cases in which a constituent larger than DP is missing.

As shown by (i), examples of attributive CD in which just a DP is missing license parasitic gaps (we are grateful to the reviewer for reminding us of this fact).

- (i) Lee bought a more expensive car [than Kim bought ___ [after seeing **pg** advertised on TV]]

Assuming that parasitic gaps are licensed by DP movement, this fact suggests that the ‘missing DP’ examples (10a–d) should in fact be analyzed in terms of pied-piping, as outlined above (which is not surprising, considering the fact that there is no operation of ‘DP ellipsis’ in English; see also note 19). However, if additional material is missing from the comparative clause, parasitic gaps are *not* licensed, indicating that DP has not moved.

- (ii) *Lee bought a more expensive car [than Kim did ___ [after seeing **pg** advertised on TV]]
 (iii) *Lee bought a more expensive car [than he had planned ___ [after seeing **pg** advertised on TV]]

While an explanation for these surprising facts is beyond the scope of this paper (but see Kennedy, to appear), we take the data as evidence that the derivation of at least the examples in (10a–d) that involve a missing VP, CP, or IP (the ‘true ellipsis’ cases) is as shown above in (11a–b), and that the challenge they present to an ECP-based analysis of attributive CD remains. (In addition to these facts, the interaction of attributive CD and pseudogapping raises independent problems for such an analysis, as we will see below.)

1.2. *Attributive CD and Pseudogapping*

Pinkham's solution to the puzzle in (12) is to reject both the movement and deletion analyses of CD, and instead develop an account in which comparatives have fully projected, but empty, structure. Under Pinkham's analysis, a comparative like (13) has the structure in (14), in which 'missing' constituents in the comparative clause are actually pronominal categories whose interpretations are fixed through coindexation with the corresponding constituents in the matrix, and the degree position in AP (indicated by Q) is directly bound by *than* or *as*.

(13) Pico's novel was more interesting than Brio's play was.

(14) Pico's novel was more interesting_i than_x Brio's play was [_{AP} Q_x PRO_i]

According to Pinkham, the binding relation between *than* and Q (the 'Q-binding relation') is constrained by subjacency: it cannot cross more than one cyclic node (where cyclic nodes are taken to be NP, AP, and CP). This analysis, like the deletion approach, has no trouble accounting for subdeletion: (3) has the structure in (15), in which the Q-binding relation crosses only one cyclic node.

(15) Wittgenstein was as unusual as_x Frege was [_{AP} Q_x noble]

Unlike the deletion analysis, however, Pinkham's approach correctly rules out (7a–d). In examples of this type, Q-binding crosses two cyclic nodes (AP and NP), as shown by (16), the structural analysis of (7a).

(16) *Pico wrote a more interesting_i novel than_x Brio wrote [_{NP} a [_{AP} Q_x PRO_i] [_N play]]

In this way, the impossibility of attributive CD in (7a–d) is explained in terms of the more general subjacency constraint.

Pinkham (1985, p. 78) extends the analysis to account for the descriptive generalization in (12) by stipulating that Q-binding is not subject to subjacency when all of the compared elements in attributive comparatives are 'maximally identical', a situation that arises only when at least the entire NP that contains the targeted AP in the comparative clause is replaced with pronominal subconstituents.⁶ As a result, even though Q-binding in

⁶ This analysis supports an ingenious explanation of why maximal identity forces material in the comparative clause to be phonologically null; i.e., why examples like (i) are unacceptable.

(i) *Pico's novel is more interesting than Brio's novel is interesting.

an example like (17), which has the structure in (18), crosses two cyclic nodes (NP and AP), the identity relation between the coindexed elements permits the structure to bypass subjacency.

- (17) Pico wrote a more interesting novel than Brio wrote.
- (18) Pico wrote a more interesting_i novel_j than_x Brio wrote [_{NP} [_{AP} Q_x PRO_i] [_N PRO_j]]

There are two problems with this analysis. First, it fails to provide an explanation of *why* maximal identity of the compared elements permits Q-binding to bypass subjacency. Because this requirement is stipulated, the analysis remains, in effect, only a restatement of the descriptive generalization in (12), not an explanation of it. Second, and more problematic, there is empirical evidence that a subjacency-based analysis of the ill-formedness of examples like (7a–d), just like an ECP-based account, is too strong. A fact that has not been previously observed in discussions of attributive comparatives is that the attributive AP in the comparative clause *can* be targeted by CD, leaving the NP that contains it intact, just in case

According to Pinkham (1985, p. 71), (i) is unacceptable because the non-pronominal category *interesting_i* in the comparative clause is c-commanded by a coindexed expression (the occurrence of *interesting_i* in the matrix), as shown in (ii).

- (ii) *Pico's novel is more interesting_i than_x Brio's novel is [_{AP} Q_x interesting_i]

In other words, (i) violates (a generalized version of) Condition C of the Binding Theory. According to Pinkham, this explains why examples like (iii), which has the structure in (iv), are unacceptable, even though the compared elements in (iii) are maximally identical.

- (iii) *Pico wrote a more interesting_i novel_j than_x Brio wrote a novel.
- (iv) *Pico wrote a more interesting_i novel_j than_x Brio wrote [_{NP} a [_{AP} Q_x PRO_i] [_N novel_j]]

Although maximal identity should allow Q-binding to bypass subjacency, the overt occurrence of *novel_j* in the comparative clause violates Condition C.

pseudogapping has also applied. This is illustrated by the contrast between (7a–d) above and (19a–d).^{7,8}

- (19)a. Pico wrote a more interesting novel than he did ___ a ___ play.
- b. Erik drives a more expensive car than he does ___ a ___ motorcycle.
- c. Jones produced as successful a film as she did ___ a ___ play.
- d. The Cubs started a more talented infield than they did ___ an ___ outfield.

⁷ Similar effects are observed in gapping (ia–b) and stripping (iia–b) constructions (examples like (iia–b) are discussed in Grimshaw 1987 in a different context):

- (i)a. Pico wrote a more interesting novel than Brio, a ___ play.
- b. The Cubs started a more talented infield than the Sox, an ___ outfield.
- (ii)a. Pico wrote a more interesting novel than a ___ play.
- b. The Cubs started a more talented infield than an ___ outfield.

For simplicity, we will focus on the interaction of attributive CD and pseudogapping in this paper, but the analysis we will develop in Section 4 extends to the constructions in (i)–(ii) as well.

⁸ Readers may object that (7a–d) and (19a–d) are not true minimal pairs because the identity of the embedded subjects has been changed. We have made this change in order to avoid the degradation of pseudogapping that is often associated with examples in which the subjects of the related clauses are distinct (see Levin 1986, pp. 35–39, Miller 1992, p. 90). For true minimal pairs, compare (19a–d) with (ia–d), which are structurally identical to (7a–d), and equally as unacceptable.

- (i)a. *Pico wrote a more interesting novel than he wrote a ___ play.
- b. *Erik drives a faster car than he drives a ___ motorcycle.
- c. *Jones produced as successful a film as she produced a ___ play.
- d. *The Cubs started a more talented infield than they started an ___ outfield.

According to Pinkham's analysis, (19a–d) should be just as unacceptable as (7a–d).⁹ As shown by (20), the structure Pinkham would assign to (19a) (ignoring for the moment the proper analysis of the missing verb), Q-binding should violate subadjacency here.

- (20) Pico wrote a more interesting_i novel than_x he did [_{NP} a [_{AP} Q_x PRO_i] [_N play]]

Since the compared elements are not maximally identical, the 'escape hatch' available to examples like (17) disappears. (19a) is acceptable, however, indicating that the subadjacency account cannot be maintained.

In addition to providing an empirical argument against the analysis proposed by Pinkham, the pseudogapping facts in (19a–d) are important for two additional reasons. First, they reinforce the conclusion that an ECP-based analysis of attributive CD is untenable, since they differ from ill-formed questions like (9a) only in the elision of the main verb. Second, they demonstrate that the unacceptability of examples like (7a–d) cannot be explained in terms of semantic 'incommensurability'. This

⁹ In fact, Pinkham (1985) explicitly marks the sentences in (ia–e), all of which involve pseudogapping, as ungrammatical.

- (i)a. They sell better shirts than they do ties.
 b. Today, she wrote a better short story than she did a poem.
 c. He makes a more convincing Hamlet than he does a Romeo.
 d. He reads better short stories than he does poems.
 e. I saw better movies than I did plays.

Our own research argues against this assessment of the data. Of eleven native speakers interviewed, ten detected a clear contrast between (ia–c) and (iia–e) (which do not involve pseudogapping), identifying (ia–e) as acceptable and (iia–c) as either marginal or unacceptable. (The eleventh informant did not detect a contrast, claiming instead that all examples were acceptable.)

- (ii)a. They sell better shirts than they sell ties.
 b. Today, she wrote a better short story than she wrote a poem.
 c. He makes a more convincing Hamlet than he makes a Romeo.
 d. He reads better short stories than he reads poems.
 e. I saw better movies than I saw plays.

type of explanation would seek to analyze, e.g., (7a) in terms of a semantic conflict, similar to the conflict involved in examples like (21), that arises when novels and plays are compared for their degree of interest. (This analysis might, for example, build on the hypothesis that the criteria used for evaluating whether a novel is interesting might differ from the criteria used for plays; see Klein 1991 and Kennedy 1999a for discussions of incommensurability).

- (21) #Pico's novel is more interesting than it is long.

While such an approach seems intuitively appealing, the pseudogapping examples in (19a–d), which make exactly the type of comparison that an incommensurability analysis of attributive CD would rule out, show that it is untenable. We therefore conclude that the constraints on attributive CD demand an explanation in terms of the syntax of comparative deletion, ellipsis, and attributive modification.

1.3. *Outline of the Paper*

The empirical observations of the previous two sections are summarized in the revised descriptive generalization in (22).

- (22) *When something goes, anything goes*
Comparative deletion in attributive comparatives is possible only if a constituent that (properly) contains the targeted AP is also eliminated from the surface representation, or if pseudogapping has also applied.

Our purpose in this paper is to construct a principled explanation of the puzzling disjunction in (22). Specifically, we will argue that the movement analysis of attributive CD presented and rejected in Section 1.1 is actually correct in its basic claim: (7a–d) are ungrammatical because they violate a constraint that prohibits extraction of attributive modifiers, which we will continue to refer to descriptively as the Left Branch Condition (LBC). We will then show that the interaction of this constraint with the grammar of ellipsis, attributive modification, and pseudogapping derives the generalization in (22). The structure and primary claims of the paper are as follows.

Section 2 provides initial empirical support for this analysis by demonstrating that in a set of Slavic languages in which questions like (9a) are acceptable – i.e., languages which do not obey the LBC in interrogatives – comparatives like (7a–d) without ellipsis in the comparative clause are also well-formed. At the same time, languages that obey the LBC, such

as Greek and Bulgarian, show exactly the same distribution of facts as English (modulo differences in the types of ellipsis operations they allow). Section 3 develops the analysis by arguing that the LBC should be formulated not in terms of constraints on Logical Form (i.e., the ECP, as in Corver 1990), thus avoiding the problems discussed in Section 1.1, but rather in terms of the principles of Phonological Form, specifically, those constraints that are responsible for certain pied-piping effects (i.e., Full Interpretation). Building on proposals in Lasnik (1995), we then show that if ellipsis is construed in terms of deletion of syntactic material at PF, the first part of the disjunction in (22) follows directly, since the syntactic structure that would trigger a Left Branch effect is not part of the PF representation. Section 4 shows that the explanation can be extended to include the second half of the disjunction in (22) by taking a deeper look at the syntax of attributive modification. We provide new evidence that the members of a certain class of attributive modifiers, which includes comparatives and other degree constructions, may occur in a position *outside* DP but within (an expanded version of) the nominal projection in the PF representation. As a result, this position can be targeted by pseudogapping, eliminating the LBC violation in the same way that it is eliminated in other ellipsis constructions.¹⁰

2. ATTRIBUTIVE CD AND LEFT BRANCH EXTRACTION

2.1. *The Syntax of Attributive Modification*

The goal of this section is to firmly establish the connection between attributive CD and left branch extractions, from both a theoretical and a descriptive perspective. In order to do this, we first make concrete our assumptions about the syntax of attributive modification generally and attributive comparatives specifically. First, we follow Abney (1987), Corver

¹⁰ A question that we will not attempt to address in this paper concerns the empirical difference between attributive CD constructions and nominal subdeletion constructions. While the former fall under the generalization in (22), the latter do not: as shown by examples like (4), nominal subdeletion constructions do not require any kind of ellipsis operation in the comparative clause. Clearly, a full explanation of the contrast between, e.g., (4) and (7a–d) requires an analysis of nominal subdeletion, something that is beyond the scope of this paper. It should be observed, however, that facts like these point to a fundamental difference between the syntax of vague determiners (*many/much, few/little*, and their comparative counterparts) and attributive modifiers. While there may be semantic reasons to categorize vague determiners with gradable adjectives (see Klein 1980), the contrast between (4) and (7a–d) indicates that there remain important syntactic differences between these two classes of prenominal expressions.

(1990, 1997), Grimshaw (1991), and Kennedy (1999a) in assuming that adjectives project extended functional structure headed by degree morphology, i.e., a member of {*er/more*, *less*, *as*, *so*, *too*, *enough*, etc.}. The basic structure of a comparative 'DegP' is shown in (23).

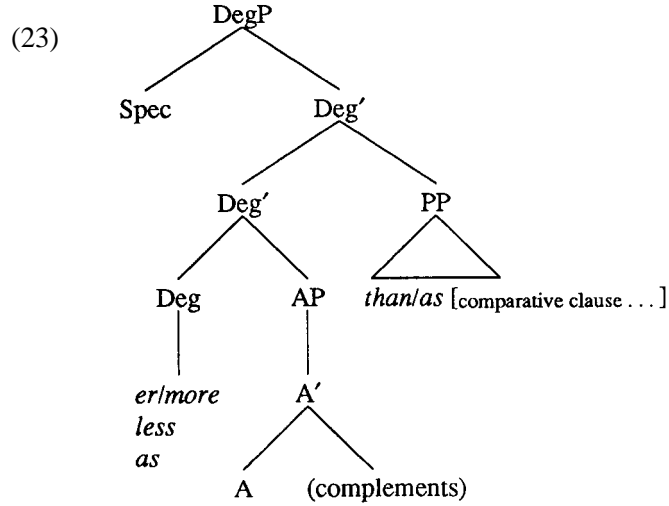

Second, we adopt Svenonius's (1992) analysis of the syntax of attributive modifiers in which the attributive DegP is left-adjoined to NP, as shown in (24).

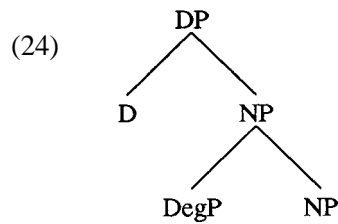

Finally, we assume that the constituent headed by *than* is base-generated as shown in (23) and extraposed to a right-adjoined position, as in Bresnan (1973).

Regarding the syntax of CD, we will assume a version of the movement analysis in which CD involves *wh*-movement of a phonologically null DegP (see Kennedy 1999a, b, for extensive discussion and justification of this assumption, as well as a fully explicit compositional semantics; see also Chomsky 1977, Klein 1980, and Larson 1988).¹¹ As pointed out

¹¹ Instead of positing a null operator, we could achieve the same result by assuming that CD constructions involve movement of an overt DegP, followed by deletion of the lexical

in Section 1.1, a result of such an assumption is that the derivation of an unacceptable attributive CD construction such as (25) should be exactly the same (in the relevant respects) as the derivation of the unacceptable question in (26).

(25) *Erik drives a more expensive car than Polly drives a motorcycle.

(26) *How expensive does Polly drive a motorcycle?

Specifically, assuming that *how* heads a DegP (Corver 1990), both (25) and (26) involve movement of a left-branch DegP out of DP, as illustrated in (27) and (28).

(27) *Erik drives a more expensive car than [Op_x Polly drives [DP a [NP t_x [NP motorcycle]]]]

(28) *How expensive_x does Polly drive [DP a [NP t_x [NP motorcycle]]]]

In Section 1.1, we demonstrated that the unacceptability of (25) cannot be explained in terms of the ECP. Such an analysis would predict all instances of attributive CD to be ungrammatical, but this prediction is falsified by the well-formedness of attributive CD constructions involving ellipsis. It follows that either the derivation of attributive CD constructions is not parallel to that of questions like (26), or that the impossibility of left branch extractions in both (25) and (26) should be explained in terms of some principle other than the ECP.

In the remainder of this section, we will make a case for the latter conclusion, by demonstrating that the first conclusion is incorrect. If the derivations of (25) and (26) are indeed parallel (as in (27) and (28)), and if the principles that rule out left branch extractions in questions like (26) apply equally to attributive CD constructions, then we expect the following pattern to emerge from a broader cross-linguistic examination of attributive CD: all other things being equal, languages in which questions like (26) are well-formed should allow attributive comparatives such as (25), while languages that are like English in ruling out (26) should also rule out comparatives like (25). The ‘all other things being equal’ constraint is crucial here, since the syntactic structure of expressions of comparison

material under local identity with the head of the comparative, a hypothesis considered and rejected in Bresnan (1975) (see also Borsley 1981). Since the choice between this sort of ‘local deletion’ approach and a null operator approach does not affect the analysis of attributive CD that we will develop in this paper, we adopt the null operator analysis for simplicity. A deletion analysis that avoids Bresnan’s objections is presented in Kennedy (to appear).

varies quite extensively across languages (see Stassen 1985 for a survey). Working within this constraint, however, we do not have to look far to see that this prediction is correct. Polish, Czech, Greek, and Bulgarian each have comparative constructions that are structurally quite similar to those in English, but these languages differ in exactly the way we expect with respect to the acceptability of left branch extractions.

2.2. *Left Branch Extractions and Attributive CD in Polish and Czech*

Unlike English, Polish and Czech permit left branch extraction of attributive modifiers. This is illustrated by the sentences in (29) and (30), which show that questions involving attributive modifiers can be constructed in one of two ways: either the full NP can be extracted, as in English (the (a) examples), or the attributive phrase can be extracted independently of the modified nominal, leaving the latter in its base position (the (b) examples).

- (29)a. Jak długą sztukę napisał Paweł? Polish
how long play wrote Pawel
- b. Jak długą napisał Paweł sztukę?
how long wrote Pawel play
 How long a play did Pawel write?
- (30)a. Jak velké auto Václav koupil? Czech
how big car Vaclav bought
- b. Jak velké Václav koupil auto?
how big Vaclav bought car
 How big a car did Vaclav buy?

If our hypothesis that attributive CD constructions involve extraction of a null operator from the same position as the phrases headed by *how* in (29b) and (30b) is correct, it follows that Polish and Czech should differ from English with respect to the acceptability of attributive CD constructions. The following set of data verifies this prediction. (31a–b) are well-formed examples of attributive CD in Polish.

- (31)a. Jan napisał dłuższy list, niż Paweł napisał sztukę.
Jan wrote longer letter than Pawel wrote play
 Jan wrote a longer letter than Pawel wrote a play.

- b. Jan kupił droższy samochód, niż Paweł kupił
Jan bought more.expensive car than Pawel bought
 motocykl.
motorcycle
 Jan bought a more expensive car than Pawel bought a motor-
 cycle.

While our informants considered these sentences somewhat complex, they did not question their overall acceptability. Czech shows a similar pattern. Although examples in which the verb in the comparative clause is the same as the matrix, such as (32a), are judged to be a bit awkward, this effect disappears for some speakers when the verbs were non-identical, as in (32b).¹²

- (32)a. ?Václav koupil větší auto než Tomáš koupil loď.
Václav bought bigger car than Tomáš bought boat
 Václav bought a bigger car than Tomáš bought a boat.
- b. Václav koupil větší auto než Tomáš ztratil loď.
Václav bought bigger car than Tomáš lost boat
 Václav bought a bigger car than Tomáš lost a boat.

Overall, our informants were united in claiming that these examples, while complex, are grammatical. The perceived awkwardness in the cases in which the same verb appears in the matrix and comparative is arguably due to the fact that there is a strong preference to leave as much material out of the comparative clause as possible. For all informants, comparatives in which the embedded verb is gapped, as in (33)–(34), were identified as more natural than their counterparts in (31a) and (32a).

- (33) Jan napisał dłuższy list, niż Paweł sztukę. Polish
Jan wrote longer letter than Pawel play
 Jan wrote a longer letter than Pawel (did) a play.

¹² In contrast, our Polish informants did not detect a noticeable difference between examples (31), in which the verbs are the same, and (i), in which they are distinct.

- (i) Jan kupił droższy samochód niż Paweł sprzedał motocykl.
Jan bought more.expensive car than Pawel sold motorcycle
 (lit. *Jan bought a more expensive car than Pawel sold a motorcycle.)

- (34) Václav koupil větší auto než Tomáš loď. Czech
Václav bought bigger car than Tomáš boat
 Václav bought a bigger car than Tomáš (did) a boat.

These facts are reminiscent of the effect of pseudogapping on attributive CD in English, a point made by our glosses of the Slavic sentences (which reflect the fact that pseudogapping is more natural than gapping in comparatives in English, though gapping is possible; see Hankamer 1979). The crucial difference is that in English, attributive comparatives that do not undergo gapping or pseudogapping (or some other kind of ellipsis operation) are uniformly unacceptable, regardless of the nature of the verbs.¹³ Our conclusion is that while the interaction of verb identity and the availability of gapping may affect the naturalness of comparatives like (31)–(34) in these languages (if gapping is an option, then sentences in which it applies are preferred to sentences in which it does not), the judgments of our informants clearly indicate that attributive CD constructions, like the corresponding questions in (29b)–(30b), are well-formed.

2.3. *Left Branch Extractions and Attributive CD in Greek and Bulgarian*

Greek and Bulgarian contrast with Czech and Polish in not permitting extraction of attributive modifiers, patterning instead with English in this respect. This is illustrated by the contrast between the (a) and (b) sentences in (35)–(36), which shows that *wh*-movement of an attributive DegP must carry along the modified NP.

- (35)a. Poso megalo aftokinito agorase o Petros? Greek
how big car bought the Petros
- b. *Poso megalo agorase o Petros ena aftokinito?
how big bought the Petros a car
 How big a car did Petros buy?

¹³ If verb identity has any effect in English, then it is the opposite of the effect it has in Polish and Czech: sentences in which the verbs are non-identical, such as (i) and (ii), are, if anything, *less* acceptable than examples in which the verbs are the same (such as those discussed in Section 1.2).

- (i) *John wrote a more interesting novel than Alex read a play.
 (ii) *John bought a more expensive car than Alex sold a boat.

- (36)a. Kolko skipa kola kupi Ivan? Bulgarian
how expensive car bought Ivan
- b. *Kolko skipa kupi Ivan kola?
how expensive bought Ivan car
 How expensive a car did Ivan buy?

If attributive CD obeys the same constraints as questions like (35)–(36), then Greek and Bulgarian should pattern with English rather than Polish and Czech with regard to the well-formedness of attributive comparatives. This is indeed the case. The examples in (37a–b) show that attributive CD in Greek cannot target only the corresponding AP (DegP) in the comparative clause.

- (37)a. *O Petros agorase ena megalitero aftokinito apoti o
the Petros bought a bigger car than+what the
 Giannis agorase ena dzip.
Giannis bought a jeep
 (lit. *Petros bought a bigger car than Giannis bought a jeep.)
- b. *I Anna dhiavase ena megalitero arthro apoti i Roxani
the Anna read a bigger article than+what the Roxani
 dhiavase ena vivlio.
read a book
 (lit. *Anna read a longer article than Roxani read a book.)

Rudin (1984a) shows that Bulgarian obeys the same constraint:¹⁴

- (38)a. *Az imam po-goljam apartamen otkolkoto ti imaš kušta.
I have bigger apartment than+how.much you have house
 (lit. *I have a bigger apartment than you have a house.)

¹⁴ Rudin (1984a) presents the contrast between (38) and (40) below (her (8a–b)) as one of several pieces of evidence (making a connection to Pinkham's (1985) observations) that comparatives in Bulgarian have essentially the same structural properties as comparatives in English.

- b. *Ivan napisa po-dobar roman otkokoto Saša napisa
Ivan wrote better novel than+how.much Sasha wrote
 drama.
play
 (lit. *Ivan wrote a more successful novel than Sasha wrote a
 play.)

The similarity among Bulgarian, Greek, and English is not limited to the unacceptability of the sentences in (37) and (38), however. As pointed out to us by Anastasia Giannakidou, the elimination of more material in the comparative clause than just the attributive DegP has the surprising effect of ‘saving’ attributive CD, just as in English. For example, (39a–b) show that attributive CD in Greek is well-formed when a constituent that contains the targeted AP is also eliminated, while (39c) shows that just the attributive AP can be eliminated when gapping has also applied (Greek does not have pseudogapping).

- (39)a. O Petros agorase ena megalitero aftokinito apoti agorase
the Petros bought a bigger car than+what bought
 o Giannis.
the Giannis
 Petros bought a bigger car than Giannis bought.
- b. O Petros agorase ena megalitero aftokinito apoti o
the Petros bought a bigger car that+what the
 Giannis.
Giannis
 Petros bought a bigger car than Giannis (did).
- c. O Petros agorase ena megalitero aftokinito apoti o
the Petros bought a bigger car than+what the
 Giannis __ ena dzip.
Giannis a jeep
 Petros bought a bigger car than Giannis did a jeep.

The examples in (40a–c) illustrate similar effects in Bulgarian: both elimination of a constituent that (properly) contains the attributive DegP (in

(40a) and (40b)) and gapping (in (40c)) have the same effect in Bulgarian that the corresponding operations have in Greek and English.

- (40)a. Az imam po-goljam apartamen otkolkoto ti imaš.
I have bigger apartment than+how.much you have
 I have a bigger apartment than you have.
- b. Ivan napisa po-dobar roman otkolkoto Saša.
Ivan wrote better novel than+how.much Sasha
 Ivan wrote a more successful novel than Sasha (did).
- c. Ivan napisa po-dobar roman otkolkoto Saša drama.
Ivan wrote better novel than+how.much Sasha play
 Ivan wrote a more successful novel than Sasha (did) a play.

2.4. Summary

There are two conclusions to be drawn from the facts discussed in this section. First, they provide a compelling array of empirical evidence that the derivation of attributive CD constructions involves *wh*-movement of a left branch modifier and that the constraints on attributive CD and *wh*-extraction of attributive modifiers are the same (Borsley 1981 reaches a similar conclusion on the basis of a study of Polish equatives). Second, they show that the option of ‘bypassing’ these constraints when ellipsis has applied does not represent a peculiarity of English grammar, but must instead reflect a more fundamental cross-linguistic property. But what property is this, and how does it have the effect of saving the derivations of sentences that the Left Branch Condition should, in principle, rule out? In order to answer these questions, we must take a closer look both at the formulation of the Left Branch Condition and at the nature of ellipsis.

3. THE LEFT BRANCH CONDITION, ELLIPSIS, AND PHONOLOGICAL FORM

3.1. *The Left Branch Condition holds at PF, not at LF*

In Section 1.1, we presented an analysis of attributive comparatives in terms of the Left Branch Condition (LBC) that we claimed was inadequate. This approach built on the hypothesis, developed most extensively

in Corver (1990), that the LBC should be formulated in terms of the Empty Category Principle (ECP). Corver's analysis is arguably the most successful attempt to date to reduce the LBC to other principles of the grammar, and it succeeds in assimilating the ill-formedness of attributive comparatives like (41) to questions like (42) (a result that the conclusions of the previous section demand), as both involve the same sort of A' dependency.

(41) *Pico wrote a more interesting novel than [Op_i Brio wrote a t_i play]

(42) *How interesting $_i$ did Brio write a t_i play?

Unfortunately, as we have already observed, this analysis fails to explain the well-formedness of examples involving ellipsis, such as the case of VP-deletion in (43).

(43) Pico wrote a more interesting novel than Brio did.

Assuming that elided material is fully specified at Logical Form (as in, e.g., Fiengo and May 1994), this example should have the LF in (44).

(44) Pico wrote a more interesting novel than [Op_i Brio did **write a t_i novel**]

This representation is structurally equivalent, in the relevant respects, to both (41) and (42): the comparative operator binds the attributive DegP position inside the (elided) DP. The problem is that if grammatical constraints hold only at the interface levels (Chomsky 1995) and, in particular, if the ECP holds only at LF, then the prediction of the analysis is that (44) should also violate the ECP, and (43) should be unacceptable.

In short, if the unacceptability of comparatives like (41) and questions like (42) is due to the same factors in both cases – a hypothesis that the cross-linguistic data presented in Section 2 strongly support – then the well-formedness of the cases involving ellipsis clearly indicates that these factors cannot be stated in terms of LF representations. Maintaining the assumption that the only levels of representation available for stating such constraints are LF and PF, we are forced to the conclusion that the principles underlying the Left Branch Condition must be formulated in terms of PF representations.

One approach to such constraints, common in phonology and in earlier syntactic work, uses specific filters on representations (see, e.g., Perlmutter's 1971 and Chomsky and Lasnik's 1977 analyses of *COMP-trace*

effects). For example, a formulation of the Left Branch Condition in terms of the filter in (45), where λ is a variable over lexical items, rules out PF representations that include an empty DegP node in attributive position when NP has lexical content.¹⁵

$$(45) \quad *[\text{NP } [\text{DegP } t][\text{NP } \lambda]]$$

This analysis is empirically superior to the ECP account, because it successfully rules out both (41) and (42), while allowing the various forms in (43) (since none of these examples contain NPs with lexical content, the structural description of the filter is not satisfied). There are a number of reasons for rejecting a formulation of the Left Branch Condition in terms of a filter like (45), however. In addition to its lack of integration into any theoretical structure, and its obvious *ad hoc* nature, there is a clear empirical argument against it: it fails to account for the effect of pseudogapping on attributive CD. The structure in (46b), for example, clearly violates the filter in (45), yet (46a) is perfectly acceptable.

- (46)a. Pico wrote a more interesting novel than he did a play.
- b. Pico wrote a more interesting novel than [Op_i he did [$_{\text{DP}}$ a [$_{\text{NP}}$ [$_{\text{DegP}}$ t] $_i$ [$_{\text{NP}}$ play]]]]

More recent work within the Minimalist Program has sought to formulate constraints on PF representations in terms of more general principles of grammar; of particular importance here is the role of *Full Interpretation* (see, in particular, Chomsky 1995, pp. 261–264 for discussion). Essentially, Full Interpretation (FI) requires all symbols in a particular interface representation to have interpretations with respect to that interface. In the case of LF representations, FI requires all expressions to have a semantic value; in the case of PF representations, FI requires (at least) all terminal nodes to have a phonological value. In the Late-insertion model of Halle and Marantz (1993), the notion of ‘having a phonological value’ is implemented in terms of the presence or absence in the lexicon of lexical items instantiating the featural combinations on syntactic objects. The syntax feeds the PF interface by supplying the latter with (an ordered set of) feature bundles which the morphology must then make sense of, namely by finding lexical items that correspond to the various feature combinations and inserting the items under the relevant nodes, which may then be

¹⁵ In its basic respects, this analysis mirrors Pinkham’s subjacency account, discussed in Section 1.2. It also suffers from the same problems as Pinkham’s analysis, as we will see below.

pronounced. (Clearly, actual pronunciation is too narrow a notion here, as phonetically null heads may or may not be able to realize certain features; this is determined by the lexicon of a particular language.) If the lexicon lacks an item for a node with a particular feature specification, the derivation crashes: the PF representation is ‘uninterpretable’ in exactly the sense described above, violating FI.

We propose that the constraints on the extraction of left branch attributive modifiers should be formulated in exactly these terms. Specifically, we claim that the locus of Left Branch effects with attributive DegPs is an uninterpretable feature combination created by agreement between a [+wh] DegP and the head of the nominal constituent in which it originates. The details of this proposal can be illustrated by considering the case of unacceptable questions such as (42).

According to Corver (1990) and Giorgi and Longobardi (1991), extraction from a nominal constituent XP must proceed via the highest specifier of XP (see also Shlonsky 1991, Aissen 1996 and Merchant 1996). In the case of movement of a [+wh] DegP from attributive position, this constraint forces movement through SpecDP (see Hendrick 1990 for essentially the same proposal). Assuming that spec-head agreement takes place between a functional head and its specifier (see Webelhuth 1992, Chung 1994), the [+wh] feature on DegP is passed to the head of DP, deriving the structure shown in (47).

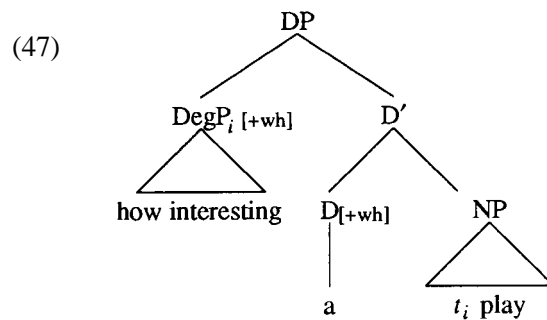

Subsequent extraction of DegP, as in (42), does not alter the feature values in DP, leading to a PF representation in which there is an occurrence of the [+wh] feature on D⁰. Such a representation, we claim, is uninterpretable, because there is no D⁰ element of English vocabulary that can be inserted into this context.¹⁶ Since Full Interpretation requires all symbols in the PF

¹⁶ It may be objected that English does have a [+wh] D⁰ element, namely *which*, yet inserting this expression into, e.g., (42) does not change its acceptability:

- (i) *How interesting_i did Brio write which t_i play?

representation to have a phonological interpretation (instantiated by lexical insertion), the derivation crashes, and the sentence is ungrammatical.

Fortunately, the grammar provides a mechanism for avoiding this result. The entire DP may be ‘pied-piped’ along with DegP, as in (48), with the result that the [+wh] feature on D^0 (as well as DegP) is checked in SpecCP and eliminated from the representation.

- (48) [how interesting_i a t_i play]_j did Brio write t_j

In this way, pied-piping (and subsequent feature checking/elimination) avoids the problems of lexical insertion that arise when the DP remains *in situ*.¹⁷

In essence, we are claiming that the impossibility of extraction of left-branch attributive modifiers in English is a consequence of the possible realizations of functional heads, rather than the role of an arbitrary filter such as the one in (45). If the locus of cross-linguistic variation is

In Section 4.2, we will provide evidence that the functional head involved in the PF violation is actually not D^0 , but rather a functional head above D^0 that is part of the extended projection of certain nominals. Since the empirical justification for this assumption relies on a set of pseudogapping facts that we discuss in Section 4.2, we ask the reader to make the temporary simplifying assumption that D^0 is the locus of the Full Interpretation violation.

¹⁷ An anonymous reviewer points out that our proposal would seem to (incorrectly) predict that a multiple *wh*-question like (i) should be ill-formed, since the embedded DP *how expensive a car* has not raised at PF, and so has not eliminated the illicit [+wh] feature on D^0 .

- (i) Who bought how expensive a car?

We see two potential explanations for the acceptability of (i). One possibility is that the embedded DP has moved and checked features, but that the upper copy rather than the lower has been deleted to satisfy the constraint that English have only one overt *wh*-phrase in SpecCP; this approach to multiple *wh*-questions is discussed in Pesetsky 1998a,b.

A second possibility builds on the principles of Optimality Theory and explains the acceptability of (i) in terms of violable constraints. While Full Interpretation may be inviolable, spec-head agreement might not be. (That spec-head agreement is violable in English is suggested by the fact that successive cyclic movement of *wh*-phrases through SpecCP does not require intermediate [+wh] complementizers.) If spec-head agreement is violable, then we get the following result. The best option in any derivation involving a [+wh] attributive DegP is to obey spec-head agreement, forcing D^0 to pick up the [+wh] feature on an inverted DegP, and then to remove this feature by raising the entire DP to SpecCP. In contexts like (i), however, where movement of DP is impossible (because of a higher ranking constraint – in this case whatever is responsible for superiority effects), the optimal derivation is one that violates spec-head agreement by not transferring the [+wh] feature on DegP to D^0 . While it is clear that either account would need to be justified by future research, what is important for our purposes is that they indicate that there are mechanisms for dealing with (i) within the general framework we have outlined here.

determined by the functional inventory, as argued in Chomsky (1995), this analysis provides the basis for a principled explanation of the cross-linguistic differences in LBC sensitivity presented in Section 2 (see also Ross 1967 and Grosu 1974). What makes Polish and Czech different from English, Greek, and Bulgarian is the array of functional elements in their respective lexicons. This proposal can be implemented in two ways. The simplest hypothesis is that the former languages contain (phonologically null) functional heads that support the combination of features which result from spec-head agreement in the extended nominal projection; the latter do not. Alternatively, we could adopt Corver's (1990, pp. 331–333) proposal that nominals in Polish and Czech lack a DP projection entirely, and are instead 'bare' NPs. If this is correct, then the explanation for the absence of Left Branch effects in Polish and Czech is not that these languages have functional morphemes that English, Greek, and Bulgarian lack, but rather that the problem of inserting such a nonexistent morpheme simply never arises.

The second approach has the obvious advantage of not having to posit a phonologically null morpheme in Polish and Czech just to account for these facts. However, since our basic analysis of Left Branch effects is consistent with either implementation, we will not take a stand here on which is the correct one. What is important to point out is that under either implementation, our analysis of LBC effects captures the typological differences among these languages with respect to the acceptability of left branch extractions in terms of differences in their functional inventories, and not in terms of some parameter that either turns the LBC on or off or regulates feature percolation in some arbitrary way.¹⁸

It should be clear that the formulation of the LBC presented here also supports an explanation of the unacceptability of attributive comparatives such as (41) in languages like English, Greek, and Bulgarian. The analysis is identical to that of (42). The [+wh] attributive DegP – here the compar-

¹⁸ An analysis in which percolation or feature-passing is hypothesized to occur in some languages (e.g., English) but not in others (e.g., Polish) is clearly wrong, since Polish has the option of pied-piping, as seen in (29a) above. Whether the pied-piping option is actually taken or not depends on extragrammatical factors: topicality, focus-background structure, etc., just as the choice between pied-piping and preposition stranding in English is largely determined by such factors (see Takami 1992 for an extensive survey). The role of the grammar is simply to determine whether certain movements are, or are not, available; here, we reduce this to a difference in the functional domain of the lexicon. (Polish, unlike English, is not *required* to pied-pipe because movement of an attributive modifier does not result in an uninterpretable feature combination in the functional morphology). Note that we are not denying the existence of feature percolation in general, we are simply claiming that typological variation in left-branch extractions should not be accounted for in terms of a 'percolation parameter'.

ative operator, rather than a DegP headed by *how* – moves through SpecDP on its way to SpecCP, as shown in (49); as a result, the [+wh] feature on the comparative operator is transferred to D⁰ via spec-head agreement.

- (49) *Pico wrote a more interesting novel than [_{CP} *Op_i* Brio wrote [_{DP} *t_i'* a_[+wh] [_{NP} *t_i* play]]]

(49), however, is an ill-formed PF representation for the same reason that (48) is: the [+wh] feature on D⁰ is uninterpretable. The representation therefore violates Full Interpretation, and the derivation crashes.

A question that this analysis immediately raises is the following: why don't attributive comparatives take advantage of the pied-piping strategy adopted in questions to eliminate the uninterpretable [+wh] feature on D⁰?¹⁹ That such a strategy is unavailable is clearly demonstrated by the unacceptability of comparatives like (50a–b).

- (50)a. *Pico wrote a more interesting novel than a play Brio wrote.
 b. *The Cubs started a more talented infield than an outfield the Sox started.

Of course, these facts are simply one manifestation of the larger generalization that null operators do not pied-pipe lexical material (see Browning

¹⁹ While the facts in (50a–b) appear to indicate that attributive CD constructions do not allow pied-piping, we have already seen that pied-piping may be possible in attributive comparatives in which only a DP is missing, such as (i), though not in examples in which larger constituents are missing (see note 5).

- (i) Pico wrote a more interesting novel than Brio wrote.

If examples like (i) are derived by raising the entire DP in which the comparative operator originates to SpecCP and deleting it under identity with the DP in the matrix clause (see note 11), the uninterpretable [+wh] D⁰ would be removed from the PF representation in the same way that it is eliminated in *how*-questions. Whether examples like (i) are derived in this way or through some kind of DP-ellipsis operation is not a question we will attempt to answer here, since our proposals are compatible with either approach. It should be pointed out, however, that a 'pied-piping plus local deletion' analysis is more appealing than an ellipsis analysis in at least one respect: it does not conflict with the fact that there is no independent ellipsis operation in English that targets DPs.

1987 and Grosu 1994 for discussion). This is illustrated by the relative clauses in (51) and (52).

(51)a. the editor [to whom Pico gave his novel]

b. *the editor [to (that) Pico gave his novel]

(52)a. the editor [whose books Pico admires]

b. *the editor [’s books (that) Pico admires]

The unacceptability of (51b) and (52b) demonstrates that the null relative operator, unlike the overt operators in (51a) and (52a), cannot pied-pipe additional lexical material. Assuming that the same principles that rule out (51b) and (52b) prohibit pied-piping in (50a–b) as well, the unavailability of pied-piping in attributive comparatives can be explained in terms of more general properties of null operators.

Although the pied-piping strategy is not available in the derivation of attributive comparatives, there is another option open to languages that need to find some way to eliminate the uninterpretable [+wh] feature introduced by the comparative operator: elimination of the constituent containing the offending feature from the PF representation. It is to this option that we now turn.

3.2. *Ellipsis is Deletion*

Our goal in this section is to show that the ‘healing’ effect of ellipsis on the derivation of attributive CD constructions follows directly from the analysis of Left Branch effects presented in the previous section, if we adopt a particular hypothesis about the nature of ellipsis: ellipsis involves deletion of syntactic structure from the phonological representation. This hypothesis has a long history in generative grammar, stretching back to early transformational work on VP-deletion and other types of ‘surface anaphora’ (see Hankamer and Sag 1976 for an overview), and has been revived in recent work by Chomsky and Lasnik (1993) and especially Tancredi (1992) and Merchant (1999).

For concreteness, we will adopt the following assumptions about the mechanics of ellipsis. Certain heads (e.g., INFL or negation in the case of VP-deletion; see Potsdam 1997, 1998) may assign a feature to their complements, which we will refer to as ϵ . This feature provides different instructions to the two interface components. At the LF interface, it requires that an identity relation hold between the marked constituent and some other constituent in the discourse (the nature of this relation

is immaterial here; it might be structural, as in, e.g., Sag's 1976 notion of *alphabetic variance*, Rooth's 1992 *redundancy relation 1*, and Fiengo and May's 1994 *reconstruction*, or semantic, as in Merchant's 1999 *e-GIVENNESS*). At the PF-interface the ϵ feature is interpreted as an instruction to delete. 'Deletion' can be construed in one of two ways: either as the complete elimination of a constituent from the representation, or as an instruction to the PF/morphology interface to forgo lexical insertion (as proposed in Wilder 1995; cf. Wasow 1972, Williams 1977, Fiengo and May 1994). We will adopt the second option here, though our analysis is completely compatible with the former.²⁰

With this background, it should be clear that ellipsis provides an alternative to pied-piping as a strategy for avoiding the PF violation underlying LBC effects. Let us again take the case of VP-deletion in attributive comparatives as a focus. According to the assumptions made so far, an example like (53) involves extraction of the comparative operator from DP in a manner that is completely parallel to the extractions in the unacceptable attributive comparative (41) and *wh*-question (42). In particular, because the comparative operator moves through SpecDP, its [+wh] feature should be passed on to D⁰, as shown in (54).

(53) Pico wrote a more interesting novel than Brio did.

(54) Pico wrote a more interesting novel than Op_i Brio did write [t'_i $a_{[+wh]} t_i$ novel]

If the representation in (54) were sent directly to PF without additional manipulations, the unchecked [+wh] feature on D⁰ would trigger a Full Interpretation violation, and the derivation would crash, as it does in (41) and (42). (54) is *not* the PF representation of (53), however; if it were, the elided VP would be pronounced. Instead, the PF of (53) is (55), in which the VP headed by *write* is deleted (struck-through text indicates deletion, i.e., the nodes that bear the ϵ feature).

(55) Pico wrote a more interesting novel than Op_i Brio did ~~write~~ [t'_i $a_{[+wh]} t_i$ novel]

Since deletion (according to the principles outlined above) blocks lexical insertion, the search for the unavailable [+wh] D⁰ item is not initiated. As a

²⁰ We are glossing over certain technical details here concerning how the ϵ feature is passed down to the individual nodes to prevent lexical insertion, assuming that the feature must be present on the heads themselves. In particular, this operation must occur after any extractions, to ensure that elements that have been removed from the ellipsis site are pronounced. See Wilder (1995), Merchant (1999) for discussion.

result, the violation of Full Interpretation that arises in attributive comparatives that do not involve ellipsis is avoided, and the derivation successfully converges at PF. In this way, ellipsis achieves the same results as pied-piping: it has the effect of eliminating an uninterpretable expression from the PF representation.²¹

Although we have focused primarily on examples involving VP-deletion, the same role is played by the other ellipsis operations involved in attributive comparatives. For example, in Greek and Bulgarian (given in (56) and (57), respectively), which do not have VP-deletion, a parallel role is played by comparative stripping (English, of course, also has this option; see Hankamer 1973):²²

- (56) O Petros agorase ena megalitero aftokinito apoti o
the Petros bought a bigger car than+what the
 Giannis.
Giannis.NOM
 Petros bought a bigger car than Giannis.

²¹ Essentially the same type of proposal is made in Lasnik's (1995) analysis of pseudogapping to license movement of direct objects to SpecAgroP without movement of V⁰ to Agro⁰. Lasnik assumes that verb movement is motivated by a strong feature on V⁰, which is an uninterpretable PF object. Since the verb is deleted in pseudogapping constructions, however, the FI violation that typically arises without overt verb movement is bypassed.

²² These cases clearly instantiate a kind of clausal ellipsis, not a prepositional *than*-clause (see Hankamer 1973). This can be seen first by the fact that the remnant DP in the *than*-clause is nominative. In addition, both Greek and Bulgarian distinguish also between prepositional *than* (Greek *apo*, literally 'from', Bulgarian *ot*, also 'from') and the subordinator found in clausal comparatives, which is formed from the prepositional *than* and a *wh*-element (Greek *apoti* < *apo* 'from' + *oti* 'the which' (see Triantaphyllidis 1996, p. 399); Bulgarian *otkolkoto* < *ot* 'from' + *kolko* 'how (much)' + *to* (relativizer) (see Rudin 1984a,b; Sławski 1962: 121)). For example, the prepositional *apo* in Greek obligatorily assigns the accusative, and cannot co-occur with clausal complements:

- (i) O Petros ine megaliteros apo {ton Gianni, *o Giannis}.
the P.NOM is bigger than the G.ACC, the G.NOM
 Petros is bigger than Giannis.
- (ii) O Petros ine megaliteros {apoti, *apo} ine o Giannis.
the P.NOM is bigger than+what than is the G.NOM
 Petros is bigger than Giannis is.

- (57) Ivan napisa po-dobar roman otkolkoto Saša.
Ivan wrote better novel than+how.much Sasha
 Ivan wrote a more successful novel than Sasha.

Recall from the discussion in Section 2.4 that attributive comparatives without some kind of ellipsis were unacceptable in both Greek and Bulgarian, just as they are in English. The reason that stripping in (56)–(57) renders the Greek and Bulgarian comparatives grammatical is the same as in English: deletion blocks lexical insertion of uninterpretable elements, bypassing a violation of FI and a PF crash.

3.3. Summary

To summarize, we have demonstrated that an analysis of Left Branch effects in terms of (uninterpretable) PF representations, together with an analysis of ellipsis as deletion of material from the PF representation, accounts for the descriptive generalization in (58) (see (12) in Section 1.1).²³

²³ In fact, the analysis presented here makes the broader prediction that ellipsis should eliminate Left Branch effects not just in comparatives, but in other environments as well. As discussed extensively in Merchant (1999), this is correct for sluicing (*wh*-movement followed by IP-deletion), as in (i).

- (i) Alex bought an expensive car, but I don't know [how expensive]_i
~~{_{IP} Alex bought [_{t'_i a t_i car]}.}~~

A reviewer notes, however, that a similar acceptability is not found with *wh*-extraction from an elided VP, supplying data similar to (ii) and (iii), illustrating an apparent contrast between left branch extraction from a deleted VP and pied-piping:

- (ii) *Alex bought an expensive car, but I don't know [how expensive]_i Ben did
~~{_{VP} buy [_{t'_i a t_i car]}.}~~
- (iii) Alex bought an expensive car, but I don't know [how expensive a car]_i; Ben did
~~{_{VP} buy t_i}.~~

However, 8 of the 10 speakers we have elicited judgments on this pair from found very little contrast at all, judging both variants unacceptable. While we do not have an explanation for the unacceptability of these examples, the well-formedness of (i) suggests that it is due to a specific property of VP-deletion (such as a stronger parallelism or identity requirement than that imposed by sluicing) rather than a Left Branch effect.

- (58) *When everything goes, anything goes*
 Comparative deletion in attributive comparatives is possible only if a constituent that (properly) contains the targeted AP is also eliminated from the surface representation.

Before moving to the next section, it should be pointed out that an analysis of ellipsis as a proform with no internal structure (see, e.g., Chao 1988, Lobeck 1995, Hardt 1993; cf. Miller 1992), together with our analysis of LBC effects, would also derive the generalization in (58). Since such analyses posit zero structure inside the elided constituent, the elided comparatives would not contain the uninterpretable feature combination that triggers a crash at PF (precisely this type of analysis is pursued in Kennedy and Merchant 1997, 1999). The main difficulty with such an approach, however, is accounting for constituents with origin sites internal to the ellipsis site, such as the comparative operator or the relative clause operator in antecedent-contained deletion constructions, whose presence is demonstrated by sensitivities to constraints on movement. The only clear solution to this problem is the one proposed by Haik (1987), who argues that the ellipsis site itself is the origin site for extracted material. However, given current theoretical assumptions, in which even subjects originate within VP, such an account is not feasible, since it would require that multiple elements have the same origin site. This problem is illustrated in a particularly acute fashion by the pseudogapping example in (59), where the object has been extracted by *wh*-movement, the subject by movement to SpecIP, and the PP by scrambling (see below).

- (59) We know what Alex will say to Beth, but we don't know what_{*i*}
 Beth_{*j*} will [_{VP} *t_j* say *t_i* *t_k*] to Alex_{*k*}!

The deletion analysis avoids these problems, since an elided VP is structurally identical to an overt one throughout the derivation, up to the point of lexical insertion. Moreover, as we will see in the next section, the interaction of pseudogapping and attributive CD provides a second type of argument in favor of the analysis of ellipsis we have presented here.

4. PSEUDOGAPPING AND ATTRIBUTIVE MODIFICATION

4.1. *The Puzzle of Pseudogapping in Attributive CD*

Pseudogapping is the name given in Levin (1986), the first systematic evaluation of this domain of data, to a construction that had been only sporadically discussed in the literature beforehand (Sag 1976 contains some examples, for instance). Examples of this phenomenon are given in (60a–f).

- (60)a. I eat pizza, but I don't seafood.
- b. Abby won't listen to her teachers, but she will to her parents.
- c. His idea might not seem crazy to you, but it does to me.
- d. I want to live with a man more than I do with a woman. [Levin 1986, p. 65]
- e. Lucy had talked about Hungarian music before Martin did about Bakunin.
- f. I respect him an awful lot, and I know he does me. [Levin 1986, p. 84]

In each case, something less than an entire VP is missing; put another way, some proper subpart of a VP, along with an auxiliary verb, is left over. We will refer to this 'left-over' constituent as the *remnant*. Recent studies have been nearly unanimous in analyzing pseudogapping as a species of VP-deletion supplemented by some mechanism to rescue the remnant, following early work by Kuno (1981) (but see Sag 1976, Levin 1986, and Miller 1992 for alternative views). For example, Jayaseelan (1990) proposes that the remnant is derived by Heavy XP Shift, Lasnik (1995) claims that it is the result of (case-driven) A-movement to the specifier of an agreement projection, and Johnson (1997) argues that it is the target of scrambling. For simplicity, we will follow Jayaseelan and Johnson in assuming that the remnant is right-adjoined to the VP, though neither the exact nature of the mechanisms deriving this configuration nor the particular landing site is material to our argument; what is important is

that pseudogapping targets verb *phrases*, as claimed by Kuno. The PF representation assigned to (60), for example, is (61).

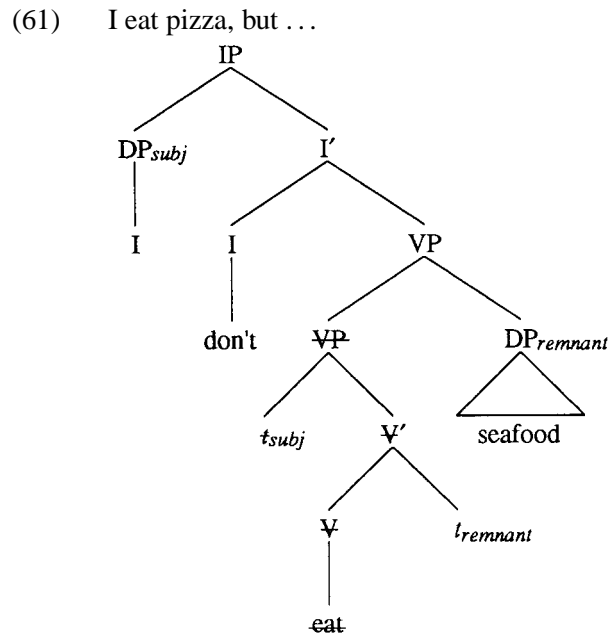

Given these assumptions about pseudogapping, together with the analysis developed in Section 3, the acceptability of the attributive CD constructions in (62a–d) is quite surprising.

- (62)a. Pico wrote a more interesting novel than he did a play.
 b. Erik drives a more expensive car than he does a motorcycle.
 c. Jones produced as successful a film as she did a play.
 d. The Cubs started a more talented infield than they did an outfield.

The problem presented by these sentences can be illustrated by considering the tree in (63), which corresponds to the PF representation of the comparative clause in (62d), given our assumptions so far.

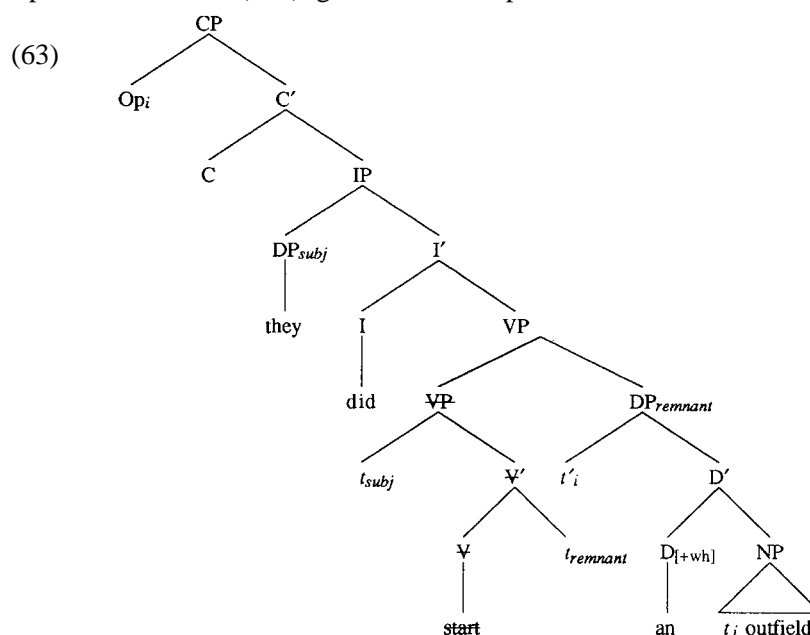

Since the remnant DP is outside the domain of ellipsis, the [+wh] feature that occurs on D^0 as a result of spec-head agreement with the extracted comparative operator should remain in the PF representation. But if the unacceptability of left branch extractions is due to an uninterpretable [+wh] feature on D^0 , as we argued in Section 3.1, (62d) should be just as unacceptable as its non-pseudogapped counterpart in (64).

- (64) *The Cubs started a more talented infield than they started an outfield.

According to our earlier claims, (64) is ungrammatical precisely because the DP from which the comparative operator is extracted has a PF representation like the remnant DP in (63). On the surface, then, the sentences in (62a–d) appear to be as problematic for our analysis as they were for Pinkham's (1982) subjacency-based account (see the discussion in Section 1.2, and cf. Kennedy and Merchant 1997, 1999, where these facts are used (incorrectly, we now believe) to motivate a *non*-deletion analysis of ellipsis). There is another possibility, however: the representation in (63) could be incorrect. In particular, if it were the case (i) that the

uninterpretable [+wh] feature introduced by movement of the comparative operator were not on D^0 , but rather on some other functional head *above* DP, and (ii) that this constituent *but not DP* were included in the ellipsis site, then the contrast between, e.g., (62d) and (64) could be explained in the following way. In the former case, but not the latter, the uninterpretable [+wh] feature is removed from the PF-representation. In the next section we present empirical evidence that supports both of these hypotheses.

4.2. *The Syntax of Attributive Modification (revised)*

The external syntax of attributive modifiers is notoriously difficult, and it is not our intention here to go deeply into any particular analysis, as most of this literature is concerned with identifying the base position of DegPs (see Svenonius 1992, Cinque 1993 and Kester 1996 for recent approaches and references). Our concern, rather, is with the position of ‘inverted’ DegPs, such as those in (65) and (66) (see Bolinger 1972, Bresnan 1973, Woisetschlaeger 1981, Abney 1987, Bowers 1987, Baker 1989, Corver 1990, Hendrick 1990), since we have claimed that it is from this position that the uninterpretable [+wh] feature involved in LBC effects is transferred to a functional head in the nominal projection.

- (65)a. [How interesting a play] did Brio write?
 b. [How tall a forward] did the Lakers hire?
 c. [How old a dresser] did Sheila find at the market?
- (66)a. I ate [too big a piece].
 b. If I ever see [that disgusting a movie] again, I’ll ask for my money back.
 c. Bob didn’t write [as detailed a proposal] as Sheila did.
 d. He took [so big a piece] that he couldn’t finish it.

As noted above, in order to explain the effect of pseudogapping on attributive CD, we must show that the structure of the DP is not as simple as we have assumed so far. Instead, there must be (at least) an additional layer of functional structure above the maximal projection headed by the indefinite determiner. To make the discussion concrete, we will refer to this structure as FP (remaining agnostic as to whether it can be identified with specific functional projections above DP that have been proposed

elsewhere in the literature; see Merchant 1996 for references), and we will assume that the specifier of FP provides the landing site for the inverted DegPs in (65) and (66). This hypothesis is illustrated by the structure in (67) (cf. Bowers 1987, Bennis et al. 1998).

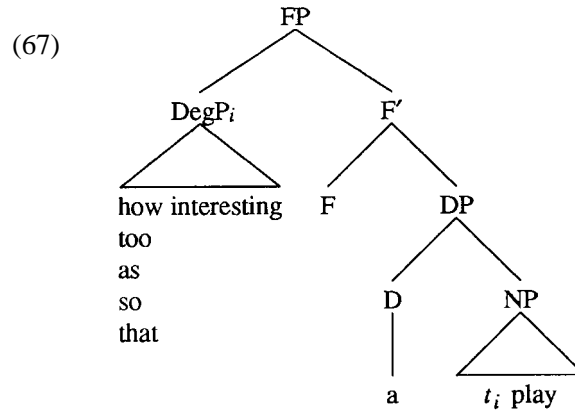

There are several pieces of empirical evidence in favor of this analysis. The first comes from a deeper examination of inversion structures like (65) and (66): all such cases of DegP inversion have alternative forms in which the apparently meaningless element *of* appears in exactly the position we posit for F^0 (see Bolinger 1972, Abney 1987, Bowers 1987), as illustrated by (68)–(69).²⁴

- (68)a. [How long of a novel] did Brio write?
 b. [How tall of a forward] did the Lakers hire?
 c. [How dumb of a guy] is he?

²⁴ There appears to be a certain amount of dialectal variation in the acceptability of *of* in these environments (see Bolinger 1972, p. 136). While we find the examples in (68)–(69) perfectly well-formed, Chris Wilder informs us that in British English, the same sentences are unacceptable. A survey of two natural language corpora suggests that in North American English at least, the use of *of* in these constructions reflects a register distinction. A search of the Brown Corpus, which consists of printed texts, turned up no examples of *of* in degree constructions like (68)–(69). However, a search of the Challenger Commission transcripts, which record the (spontaneous) utterances of the participants in the 1986 Congressional hearings on the destruction of the Challenger space shuttle, turned up a number of naturally-occurring instances of *of* in contexts parallel to (68)–(69), some of which are repeated in (i)–(iii). (Note that (i) contains two occurrences of the same

- (69)a. I ate [too big of a piece].
- b. If I ever see [that disgusting of a movie] again, I'll ask for my money back.
- c. Bob didn't write [as detailed of a proposal] as Sheila did.
- d. He took [so big of a piece] that he couldn't finish it.

This *of* is clearly not the usual case-assigning possessive *of*, nor the *of* that assigns case to arguments of nouns, nor the partitive *of*, nor any *of* which mediates a semantic relation between its complement and some other head. Instead, this *of* is most similar to the *of* found in the *N of a N* construction (*a bear of a guy*, Dutch *een beer van een kerel*), discussed extensively in Bennis et al. (1998). Bennis et al. argue persuasively that this morpheme is the realization of a functional head within the nominal phrase, which they identify as a (nominal) copular element. For them, as for Kayne (1994), the first N (*bear* in *a bear of guy*) in the construction is a predicate and undergoes predicate inversion around the 'subject' *guy* (the second N). The strength of the syntactic and semantic parallels to the DegP inversion constructions listed above – in both constructions, the fronted XP is a predicate, and the second expression (our DP; Bennis et al.'s 'subject') must be indefinite (as indicated by the ill-formedness of phrases like **too big (of) those pieces*, **as detailed (of) Bob's proposal*, etc.; see Bresnan 1973 for extensive discussion of this constraint) – leads us to conclude that the facts in (68)–(69) provide one piece of evidence in favor of the structure in (67).²⁵

nominal which differ only in the presence/absence of *of*, nicely illustrating the optionality of 'of-insertion'.)

- (i) It was just a judgment question as to *how big of a risk* it was, and there were different opinions about *how big a risk* it was. [Challenger Commission transcripts, ch.5.138]
- (ii) Landing on a runway and getting *too high of a crosswind* may cause us to deviate off of the runway and so forth, and so we have a crosswind limit during ascent [sic], assuming a nominal flight. [ibid., ch.1.2]
- (iii) If they do see something, and they can just barely feel it with their fingernail, I don't think there's any measuring tool that we could have to measure that, *that small of a scratch*, you know, really. [ibid., ch.5.60]

²⁵ There are also a number of differences between the *N of a N* construction and the DegP inversion constructions. First, in the former, but not the latter, the *of* is obligatory.

A second, and even more striking, piece of evidence in support of the hypothesis underlying the structure in (67) – that DegP inversion moves DegP out of DP to the specifier of a higher functional head in the nominal projection – comes from a set of facts brought to our attention by John Frampton. These facts, illustrated by (70)–(72), show that an attributive modifier can be caught up in the ellipsis process that generates pseudogapping structures. In each example, the (a) sentence is ambiguous between the reading paraphrased in (b) and the one in (c).²⁶

- (70)a. I have written a successful play, but you have __ a novel.
- b. I have written a successful play, but you have written a novel.
- c. I have written a successful play, but you have written a successful novel.
- (71)a. The Cubs need left-handed pitchers more than they do __ hitters.
- b. The Cubs need left-handed pitchers more than they need hitters.
- c. The Cubs need left-handed pitchers more than they need left-handed hitters.
- (72)a. I buy expensive shoes because I don't __ suits.
- b. I buy expensive shoes because I don't buy suits.
- c. I buy expensive shoes because I don't buy expensive suits.

Second, for Bennis et al., both the *of* and *a* are realized in a single functional position: the functional head housing the determiner raises to the F housing *of*, and these are spelled out as *of + a*. In our case, however, there is strong evidence for separating the head of *of* and that of *a* as we have done in (67), which we will discuss below (see note 31).

²⁶ Similar effects are observed in gapping. Thus (ia), like its pseudogapping brethren above, has the interpretation in (ib) or the one in (ic).

- (i)a. Sam wrote a successful play, and Vic __ a novel.
- b. Sam wrote a successful play, and Vic wrote a novel.
- c. Sam wrote a successful play, and Vic wrote a successful novel.

We assume that the derivation of sentences like (ia) parallels those of their pseudogapping relatives, modulo differences in the target of ellipsis (a VP in pseudogapping; a clausal/inflectional node in gapping).

The (b) readings are completely unsurprising, given the analysis of pseudogapping we have adopted (or any other analysis): the remnant DP is removed from VP, and the VP is deleted. The (c) readings, however, are quite unexpected, since pseudogapping appears to be ‘reaching inside’ the remnant DP to delete the attributive modifier along with VP.

The availability of such readings is further demonstrated by examples involving the verb *make*. In order for this verb to have the type of ‘evaluative’ interpretation illustrated in (73a), its complement must have an attributive modifier; (73b), without the modifier, is extremely odd (on the relevant reading).²⁷

(73)a. Peaches make delicious tarts.

b. ??Peaches make tarts.

The attributive modifier can be omitted from the complement, however, in pseudogapping contexts. Compare, for example, (74a) (which has the interpretation paraphrased in (74c)) with (74b): neither contains an overt occurrence of the attributive adjective, yet only the former is felicitous on the evaluative reading of *make*.

(74)a. Peaches make delicious pies more consistently than they do ___ tarts.

b. ??Peaches make delicious pies more consistently than they make tarts.

c. Peaches make delicious pies more consistently than they make delicious tarts.

These facts are parallel to those in (70)–(72), and follow if (74a) is derived from a representation like (74c), and both the VP and the attributive adjective are targeted by pseudogapping.

²⁷ Interestingly, *N of a N* constructions also make good complements of this evaluative sense of *make*:

(i) Those peaches will make a hell of a tart!

If *N of a N* and inverted DegP constructions have a similar syntax (i.e., if both project functional structure above DP, as in (67)), then these facts could be accounted for by the hypothesis that whereas most verbs allow either a DP or an FP complement, evaluative *make* requires an FP.

In order to explain this array of facts within the context of standard assumptions about nominal structure, it would be necessary to assume that ellipsis in, e.g., (70a) can target an attributive DegP, as shown in (75).

- (75) I have written a successful play, but you have [_{VP} written t_j] [_{DP} a [_{NP} ~~successful~~] [_{NP} novel]]]_i

That such an analysis is untenable is clearly indicated by the fact that the (b) sentences are *not* ambiguous; if ellipsis could target DegP, however, the (b) sentences could also be derived from underlying representations corresponding to the (c) sentences. (Similarly, (74b) would be incorrectly predicted to be acceptable.) This fact also demonstrates that the ambiguity of the (a) sentences reflects an interaction between attributive modification and the grammar of ellipsis, rather than a general strategy for recovering adjective meanings. If such a strategy were available, independent of ellipsis, then the (b) sentences should be just as ambiguous as the (a) sentences, and (74b) should be felicitous.

While an exploration of the full range of facts in this area is beyond the scope of this paper, it is clear that the syntactic structure in (67) provides a means of accounting for the data discussed so far. If this structure is available, then the (c) readings of the (a) sentences in (70)–(72) and (74) can be derived in the following way: the attributive DegP moves to SpecFP, as in the inversion structures above, then DP scrambles out of VP and VP deletes, as per the usual mechanics of pseudogapping. The PF representation of (70a), illustrating the steps in this analysis, is shown in (76).

- (76) I have written a successful play, but you have [_{VP} ~~written~~ [_{FP} [_{DegP} successful]_i F^θ t_j]] [_{DP} a t_i novel]_j

Clearly, many questions about the pseudogapping constructions in (70)–(72) and (74) remain. In particular, the question of what regulates DegP inversion needs to be addressed, as well as questions about the nature of the movement operation that creates pseudogapping remnants.²⁸ Although answering these questions is not trivial, it is also not necessary for our purposes: the crucial point is that these facts provide clear evidence that an attributive DegP can be stranded inside the verb phrase in pseudogapping constructions when the DP from which it originates is removed. The syntactic structure in (67) provides a principled means of

²⁸ The first question asks which DegPs must, can, and cannot move to SpecFP, and when? For example, while DegPs headed by *how* and *as* must invert (i), overt inversion of DegPs headed by *more* and *enough*, as well as inversion of DegPs with intensifiers like

deriving this result, as it introduces a position (SpecFP) outside DP but inside the elided constituent to host the attributive DegP.²⁹

4.3. *The Puzzle Solved*

The postulation of an additional layer of functional structure in the extended nominal projection is not only independently needed to host the morpheme *of* in constructions like (68)–(69) and to account for the ambiguities in (70)–(72), it also provides a theoretical framework within which an explanation of the effect of pseudogapping on attributive CD along the lines of the one we sketched at the end of Section 4.1 can be implemented. The explanation relies on the same set of assumptions as the analysis developed in Section 3, with one important modification: the Full Interpretation violation underlying Left Branch effects is due to the absence of a [+wh] F⁰ head in the English lexicon, rather than the absence of a [+wh] D⁰ head. This refinement not only obviates the objection to our earlier analysis (pointed out in note 16) that English possesses a [+wh] determiner (namely quite is marked (ii), and overt inversion of ‘bare’ DegPs is impossible (iii) (some of these are from Bresnan 1973, pp. 287–288).

- (i)a. He’s {too, as} reliable a man.
- b. *He’s a {too, as} reliable man.
- (ii) ?He’s {more reliable, reliable enough, quite reliable} a man.
- b. He’s a {more reliable, reliable enough, quite reliable} man.
- (iii)a. *He’s reliable a man.
- b. He’s a reliable man.

The framework we have developed here suggests a promising line of inquiry into these facts. If it can be shown that inversion in, e.g., (iia) is ruled out by a constraint on PF representations, then the fact that such inversion occurs in the (c) readings of (70a)–(72a) is not problematic: ellipsis would bleed this constraint, as it does in left branch extractions.

The second question is central to the scrambling analysis of pseudogapping: why is it that in many cases scrambling is possible only if deletion also applies? Johnson (1997) recognizes this question (see also Miller 1992, who brings this issue up as a challenge to a scrambling-based analysis), and although we acknowledge the interesting similarity to the question we began this paper with (why is attributive CD possible only if ellipsis also applies?), we will have nothing to add to Johnson’s speculations here (though see Lasnik 1995 for relevant discussion).

²⁹ We should emphasize that we are not assuming that *all* nominals project structure above DP: the facts we have discussed here indicate only that certain types of indefinites have the extended ‘F-projection’ (those indefinites that Bresnan 1973 refers to as ‘predicative’).

which), it also provides a means of explaining the effect of pseudogapping on attributive CD in the same way as that of other ellipsis operations, by taking advantage of the extra structure provided by FP. Specifically, if the position in the nominal projection that hosts a [+wh] DegP is SpecFP, as argued in the previous section, and if the locus of Left Branch effects is an uninterpretable [+wh] feature on F^0 , derived through spec-head agreement, then the well-formedness of attributive CD constructions involving pseudogapping is due to the fact that DP can scramble out of the deleted VP, leaving FP behind. Since FP (with its unrealizable [+wh] F^0 head) is then deleted along with VP, the Full Interpretation violation is avoided, and the structures are correctly predicted to be well-formed.

For illustration of the analysis, consider the derivation of (77).

(77) Pico wrote a more interesting novel than he did a play.

First, within the extended DP projection, the [+wh] DegP (the comparative operator) raises to SpecFP, transferring its [+wh] feature to F^0 via spec-head agreement.³⁰ Next, the movement operation that creates pseudogapping remnants applies to DP, raising it to a VP-adjoined position. Crucially, this scrambling operation leaves the FP structure behind, an option that the ambiguous pseudogapping constructions discussed in Section 4.2 showed to be available. At PF, VP deletion may apply, yielding the representation in (78).

Since deletion effectively eliminates the otherwise fatal [+wh] F^0 head inside VP, (78) avoids the FI violation that this uninterpretable expression should trigger. The result of this analysis, then, is that the pseudogapping facts in (62a–d) are explained in exactly the same way as the other ellipsis constructions discussed in Section 3: in all of these constructions, ellipsis, formalized as deletion of material in the PF representation, removes a feature complex that would otherwise violate the interface constraints.³¹

³⁰ That movement to SpecFP is driven by some feature on F^0 itself, rather than by the *wh*-criterion as supposed by Hendrick 1990, is justified not only theoretically (Chomsky 1995 proposes that movement is driven only by the attracting feature), but also empirically: as noted in Section 4.1, inversion happens with a variety of [-wh] DegPs.

³¹ We are now also in a position to see why F^0 and D^0 must be kept separate, in contrast to the head-movement account of Bennis et al. 1998, in which analogous elements are realized on a single head position corresponding to our F^0 (see note 25). As is clear from the structure in (78), if D^0 were to raise to F^0 (prior to scrambling of the DP remnant), we would expect to see bare singular remnants in pseudogapping, contrary to fact. Moreover, although the overt realization of F^0 (*of*) is optional otherwise, it is never found in pseudogapping contexts, indicating that F^0 must be included in the deleted material:

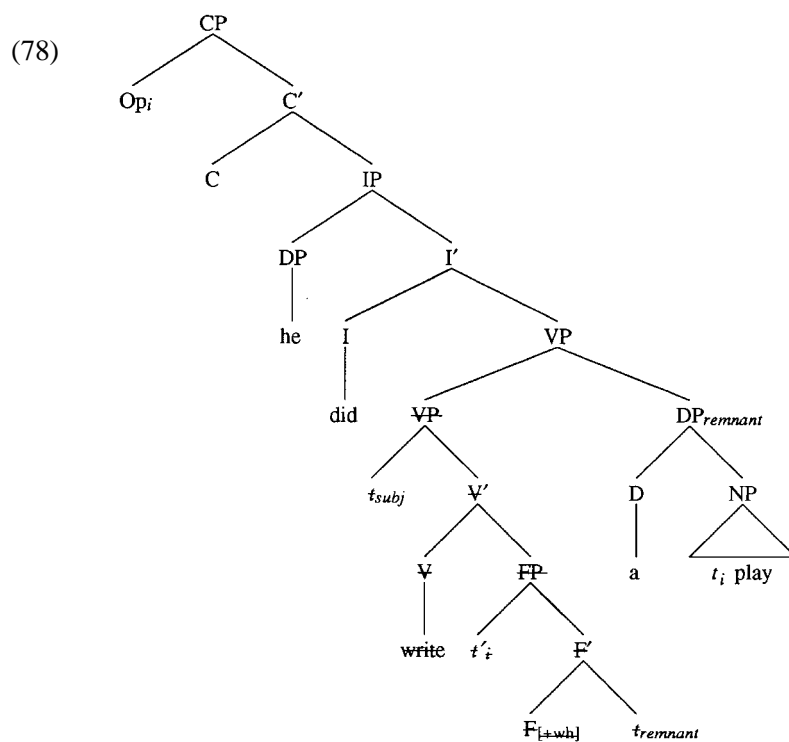

The analysis of pseudogapping and attributive CD that we have presented here also extends to an explanation on the effect of gapping in attributive CD constructions in Greek and Bulgarian, discussed in Section 2.4 above (as well as examples of gapping in English; see note 7). Recall

- (i) *Bob didn't write as detailed of a proposal as Sheila did of an outline.
(cf. Bob didn't write as detailed (?of) a proposal as Shiela did an outline.)

Whereas other structural analyses would have to posit additional constraints to rule out examples like (i), the unacceptability of this example follows straightforwardly from our claim that DP is the target of scrambling in pseudogapping constructions involving attributive CD.

We should point out that our analysis does not rule out the possibility of FP remnants in other pseudogapping constructions in principle; indeed, examples like (ii) indicate that such constructions are possible.

- (ii) Bob wrote too long of a proposal because Sheila did too short of an outline.

The analysis does, however, correctly predict that FPs are not licit remnants in attributive CD constructions (as in (i)), as this would involve leaving the uninterpretable [+wh] F⁰ head in the PF representation, triggering a Left Branch effect.

that Greek and Bulgarian are like English, both in ruling out attributive CD constructions that do not involve any kind of ellipsis and in allowing examples in which gapping has applied. This is illustrated by the contrasts in (79a–b) (Greek) and (80a–b) (Bulgarian).

(79)a. *O Petros agorase ena megalitero aftokinito apoti o
the Petros bought a bigger car than+what the
 Giannis agorase ena dzip.
Giannis bought a jeep
 (lit. *Petros bought a bigger car than Giannis bought a jeep.)

b. O Petros agorase ena megalitero aftokinito apoti o
the Petros bought a bigger car than+what the
 Giannis __ ena dzip.
Giannis a jeep
 Petros bought a bigger car than Giannis did a jeep.

(80)a. *Ivan napisa po-dobar roman otkolkoto Saša napisa
Ivan wrote better novel than+how.much Sasha wrote
 drama.
play
 (lit. *Ivan wrote a more successful novel than Sasha wrote a play.)

b. Ivan napisa po-dobar roman otkolkoto Saša __ drama.
Ivan wrote better novel than+how.much Sasha play
 Ivan wrote a more successful novel than Sasha (did) a play.

The explanation of these contrasts is essentially the same as that of the pseudogapping constructions in English. We assume that the unacceptable examples in (79a) and (80a) are ill-formed for the same reason that they are in English: neither the Greek nor the Bulgarian lexicon contains a [+wh] F⁰ element, therefore movement of the comparative operator through SpecFP triggers a Full Interpretation violation and a PF crash. In (79b) and (80b), however, ellipsis eliminates the uninterpretable material from the PF representation: assuming that gapping involves scrambling of DP to a clause-adjoined position, followed by deletion of a constituent above VP but below the surface position of the subject (which, like the internal remnant, may have extracted from its canonical position; see Sag 1976 and

Pesetsky 1982 for discussion), the uninterpretable [+wh] F⁰ head is deleted (along with FP).

4.4. *Summary*

To conclude this section, we return to the descriptive generalization established in Section 1 (see (36)) and repeated here, which we are now in a position to explain:

- (81) *When something goes, anything goes*
 Comparative deletion in attributive comparatives is possible only if a constituent that (properly) contains the targeted AP is also eliminated from the surface representation, or if pseudogapping has also applied.

In Section 3, we demonstrated that the first part of this generalization follows from a formulation of the Left Branch Condition in terms of well-formed PF representations and an analysis of ellipsis as deletion of material from the PF representation. In this section, we showed that this account can be extended to include the second half of the disjunction if we adopt a more articulated syntactic analysis of attributive modification constructions, in which attributive modifiers raise to the specifier of a functional head within the extended nominal projection, but above DP, an analysis that finds independent motivation from the distribution of functional *of*, the possibility of including attributive modifiers in the material targeted by pseudogapping, and the properties of evaluative *make*. The puzzling disjunction in (81) is thus explained in terms of the interaction of three independent components of the grammar: Full Interpretation (at the PF interface), the principles of ellipsis, and the syntax of attributive modification.

5. ADDITIONAL SUPPORT FOR THE ANALYSIS

5.1. *Ellipsis and Attributive CD in a Broader Context*

Despite the breadth of the generalization in (81), the analysis of attributive CD that we have developed in this paper does not actually predict that pseudogapping and other forms of ellipsis should *always* license attributive CD. Instead, it makes a much more restricted claim: attributive CD should be acceptable only when ellipsis targets a constituent containing FP. It follows that attributive CD should be impossible in contexts in which FP is excluded from an elided constituent, since the result would be that the uninterpretable [+wh] F⁰ element would remain part of the PF representation. Two types of examples show that this prediction is borne out.

The first involves prepositional phrases (we are grateful to two anonymous reviewers for bringing the following facts to our attention). As shown by (82a–b), PPs can be remnants in pseudogapping.

- (82)a. Jones acts in films more often than she does ___ [PP in plays].
- b. Pico was working on his novel at the same time that I was ___ [PP on my play].

Since the complement of P^0 is a nominal constituent, it follows that attributive CD should be impossible when the compared constituent in the comparative clause is in an overt PP, since this would indicate that FP is part of the PF representation, in violation of Full Interpretation. (83a–b) show that this is indeed the case, while (84a–b) show that if the PP is elided, the constructions are perfectly acceptable, as expected.

- (83)a. *Jones acts in better films than she does in plays.
- b. *Pico was working on a more interesting novel than I was on a play.

- (84)a. Jones acts in better films now than she used to.
- b. Pico was working on a more interesting novel than I was.

The second context involves subjects (thanks to Chris Wilder and an anonymous reviewer for reminding us of the importance of these examples). Since the subject position is typically outside the domain of ellipsis, our analysis predicts that attributive CD in subject position should be unacceptable. The examples in (85) confirm this prediction.

- (85)a. *Better short stories were published this year than novels were.
- b. *Fatter boys were born in this hospital than girls were.
- c. *A longer table was ordered than a desk was.

Given the unacceptability of (85a–c), however, the relative acceptability of the sentences in (86) might come as a surprise.

- (86)a. Better short stories were published this year than novels.

- b. Fatter boys were born in this hospital than girls.
- c. A longer table was ordered than a desk.

In fact, the data in (86) are expected within our analysis. These sentences involve comparative stripping, which we assume involves movement of the remnant expression to a clause-adjoined position, followed by IP-deletion (Hazout 1995; cf. Sag 1976, Pesetsky 1982, and Reinhart 1991). As already observed (see note 7), examples of comparative stripping involving internal arguments, such as (87), are just as acceptable as the corresponding pseudogapping constructions.

- (87) The Cubs started a more talented infield than an outfield.

Assuming that the extraction options available to stripping are the same as those available to pseudogapping and gapping (clearly the null hypothesis), the well-formedness of (87) can be explained in the same way as that of the comparable pseudogapping construction: this sentence has a derivation in which the DP *an outfield* is moved out of FP to a clause-adjoined position, and then IP is deleted, eliminating the uninterpretable $F^0_{[+wh]}$ element. The PF-representation associated with this derivation is shown in (88) (here we assume that the remnant moves to the left and adjoins to IP, but this is not crucial to the analysis).

- (88) The Cubs started a more talented infield than [_{CP} *Op_i* [_{IP} [_{DP} *an* *t_i* outfield]_{*j*}]] ~~the Cubs started [_{FP} $F^0_{[+wh]}$ *t_j*]]]~~

The subject-oriented stripping examples in (86a–c) can be explained in exactly the same way, the only difference being that these sentences involve movement of the remnant DP out of the FP in subject, rather than object, position.

5.2. *String-vacuous Pseudogapping*

At first glance, sentences like (89a–b) seem to provide an argument against the analysis of attributive CD and Left Branch effects that we have presented in this paper, since it appears that they do not involve ellipsis. (In fact, (89a) was originally presented by Bresnan 1975, p. 50 as an argument *against* a movement analysis of CD and in favor of the unbounded deletion account; see note 3.)

- (89)a. George is as phony a hatcheck girl as Mildred is a bouncer.
- b. Damon is a better lobsterman than he is a cook.

If this is the case, then given our assumptions about the derivation of the comparative clause, the PF-representations of (89a–b) should contain uninterpretable [+wh] F⁰ heads, and our analysis incorrectly predicts that these sentences should show Left Branch effects. There is good evidence, however, that (89a–b) are actually pseudogapping constructions in disguise.

One well-known characteristic of VP-deletion in English is that it blocks auxiliary reduction (contraction) to its immediate left (King 1970, Hankamer and Sag 1976):

- (90)a. Martin won't drive, but I {*'ll/will}.
 b. Billy's leaving today, and Mildred {'s/is} tomorrow.

Such reduction is perfectly possible before predicate nominals, however:

- (91) George is a dog-catcher, and Mildred's a bouncer.

Using auxiliary reduction as a test for the presence of ellipsis, then, it becomes clear that the comparative clauses in (89a–b) behave as though they have undergone VP-deletion, which we have assumed (following Kuno 1981) to be the ellipsis operation involved in pseudogapping. As shown by (92a–b), auxiliary reduction in these examples is impossible.

- (92)a. *George is as phony a hatcheck girl as Mildred's a bouncer.
 b. *Damon is a better lobsterman than he's a cook.

Bresnan (1975, p. 50) takes these facts to indicate that the 'gap' in examples like (89a–b) (created by unbounded deletion in her analysis) is immediately to the left of the DPs *a bouncer* and *a cook*, in exactly the position than an inverted DegP would appear. We agree with Bresnan that the impossibility of contraction indicates that deletion has applied; we disagree in the category of the deleted constituent.

First, if CD actually did involve unbounded deletion, then it would be possible (contrary to fact) to delete attributive DegPs across the board; this is Pinkham's (1982) original argument against Bresnan's analysis, summarized in Section 1.1. That the deletion operation involved in (92a–b) targets VP becomes apparent once we consider how exactly pseudogapping would work in these examples. Clearly, there must be some mechanism for ensuring that the verb is not included in the deleted material, since it remains in the phonological representation. In order to derive this result,

we assume that the verb originates in VP (or possibly as the head of a predicative projection; cf. Bowers 1993), then raises to I^0 . Pseudogapping then proceeds as usual: the remnant DP adjoins to VP, and the lower segment of VP is deleted. The result is, in effect, ‘string-vacuous pseudogapping’. This is illustrated by the tree in (93), which corresponds to the proposed PF representation of the comparative clause in (89a).

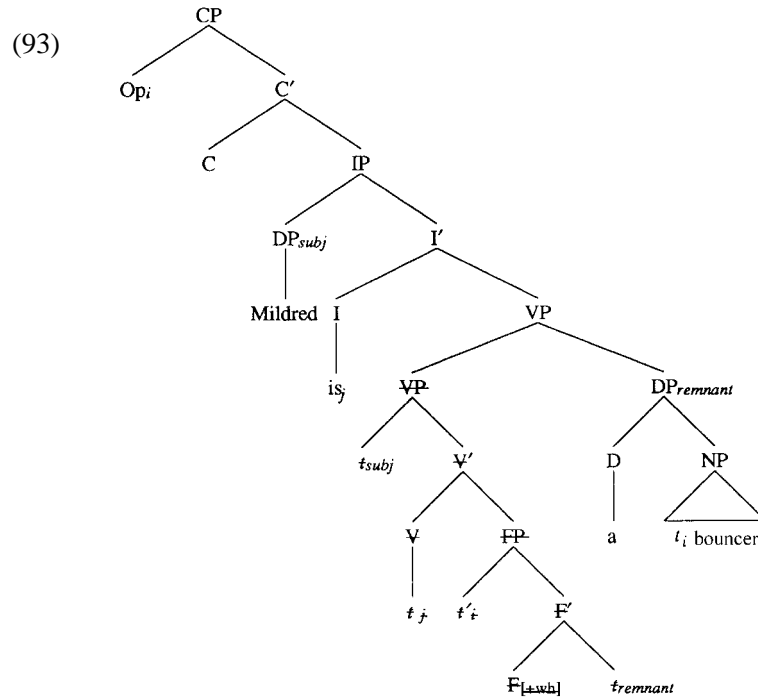

This analysis makes the following prediction: if movement of V to I is blocked by the presence of another constituent in I^0 , but *be* is overt, then attributive CD should be impossible. The following examples, in which I^0 is occupied by the morpheme *to*, verify this prediction:

- (94)a. *George is as phony a hatchcheck girl as Mildred seems to be a bouncer.
- b. *Damon wants to be a better lobsterman than he wants to be a cook.

We conclude, then, that (89a–b) involve (string-vacuous) pseudogapping. As such, they do not constitute an argument against a movement analysis of comparative deletion constructions, but rather provide additional support

for the analysis of attributive CD that we have developed in this paper, since they show exactly the set of properties that we expect to find in constructions in which attributive CD is acceptable.³²

5.3. *Restrictions on DegP Inversion*

A final piece of evidence that our analysis is on the right track comes from an interesting parallel between attributive CD constructions involving pseudogapping and the availability of the ‘elided attributive’ readings of pseudogapping constructions discussed in Section 4.2 (see (70)–(72)). Although pseudogapping allows all sorts of remnants (see (60a–f)), not all remnants show the same types of ambiguities as the examples in (70)–(72). For example, all of the sentences in (95) are perfectly acceptable, but none have readings in which the attributive DegP in the antecedent clause modifies the remnant nominal in the second clause.

- (95)a. I have written a successful play, but you have __ 10 novels. (*≠ 10 successful novels*)
- b. The Cubs need a left-handed pitcher more than they do __ the hitter being offered by St. Louis. (*≠ the left-handed hitter being offered by St. Louis*)
- c. [CONTEXT: staring at a very expensive Italian suit in a shop window]
I bought expensive shoes because I didn’t __ that suit. (*≠ that expensive suit*)

In order to derive the elided attributive reading in pseudogapping, it must be the case that DegP raises to SpecFP (see the discussion in Section

³² Potential counterexamples to our analysis come from sentences involving evaluative *make* ((ia) is discussed in Pinkham 1985):

- (i)a. They make better police dogs than they make pets.
- b. She’ll make a stronger pitcher than she’ll make a catcher.
- c. Let’s hope that this idea makes as interesting a paper as it makes an abstract.

While we do not have an explanation for these facts, it seems clear that they reflect an idiosyncratic property of evaluative *make*. We should also point out that one of the anonymous reviewers of this paper finds the sentences in (ia–c) unacceptable, unless pseudogapping removes the occurrence of *make* in the comparative clause and replaces it with a form of *do*.

4.2). The facts in (95), together with the data in (70)–(72), can therefore be taken as evidence that such movement is limited to FPs in which D^0 is either null (as in bare plurals) or the singular indefinite determiner (cf. Bresnan 1973). While an explanation for this constraint is beyond the scope of this paper, we can nevertheless make the following prediction. Since the acceptability of attributive CD constructions involving pseudogapping is also dependent on DegP inversion, the class of remnants that permit elided attributive readings should be the same as the class of licit remnants in attributive CD constructions with pseudogapping. The examples discussed in this paper, all of which involve indefinites and bare plurals, together with the data in (96), indicate that this is indeed the case.

- (96)a. *I have written a more successful play than I have ___ 10 novels.
- b. *The Cubs need a more talented pitcher than they do ___ the hitter being offered by St. Louis.
- c. *I bought more expensive shoes than I did ___ that suit.

6. CONCLUSION

Driven by concerns of observational adequacy, this paper provided a new analysis of a complex array of facts involving the syntax of attributive comparatives that has defied earlier attempts at explanation. On the basis of data from English, Polish, Czech, Greek, and Bulgarian, we derived two empirical generalizations: first, that there is a direct correlation between left-branch extractions in interrogatives and the acceptability of attributive comparative deletion (CD) constructions, and second, that languages in which left-branch extractions are impossible can ‘bypass’ this constraint by eliding a constituent that includes the extraction site. We showed that the first fact follows from an analysis of the comparative operator as a DegP originating inside DP, identical to the DegP found in attributive adjectival modification: *wh*-extraction of such elements – either in questions or in comparatives – is deviant. The second fact follows from the hypotheses that left-branch extractions are sensitive to constraints on PF representations and that ellipsis involves deletion. As such, ellipsis provides a means of avoiding these constraints.

In terms of empirical coverage alone, our account is considerably more successful than its predecessors, as it not only provides an explanation of the basic ellipsis facts, but also of the effect of pseudogapping (and gapping) on attributive CD. At the same time, the proposals we have advanced

are integrated into a larger theoretical base and have several important theoretical consequences.

First, at least one traditional island constraint – the one governing the extraction of left-branch attributive modifiers (the other effects subsumed by Ross's original Left Branch Condition have been argued by many researchers not to form a unitary phenomenon; see, e.g., Grosu 1974 and Corver 1990) – must be formulated in terms of PF representations, rather than LF representations, as standardly assumed. Specifically, this type of left-branch effect arises when the lexicon cannot realize a certain feature bundle instantiated by the syntactic derivation, triggering a violation of Full Interpretation at the PF interface. This proposal both builds on recent work on the syntax-morphology/phonology interface (Halle and Marantz 1993), and provides a means of explaining cross-linguistic variation solely in terms of differences in the (functional) vocabularies of particular languages (Chomsky 1995).

Second, we have claimed that ellipsis must be analyzed as deletion of material from the PF representation. A prerequisite of this analysis is that elided material is part of the syntactic representation of a sentence prior to deletion (and therefore included in the LF representation, given standard assumptions about the relation between PF and LF). In other words, ellipsis involves syntax; ellipsis is not just the recovery or instantiation of a constituent meaning (as in e.g., Dalrymple et al. 1991, Hardt 1993, Jacobson 1992, Hendriks and de Hoop 1998). That ellipsis must involve syntax is demonstrated by the important new phenomenon that this paper introduced: the interaction of attributive CD and pseudogapping. As we pointed out at the end of Section 3, an analysis of ellipsis in terms of 'empty syntax' (plus recovery of syntactic structure at LF or semantic content) could account for the well-formedness of attributive comparatives in which a constituent that properly includes DegP is removed from the comparative clause. Since such analyses do not posit syntactic structure for elided constituents, the PF violation involved in left-branch effects could never arise. However, these accounts have no explanation for the well-formedness of attributive CD constructions involving pseudogapping. The explanation of these facts relies crucially on the assumption that there is a syntactic position outside the remnant DP, *but inside the target of ellipsis*, to which an attributive modifier may move (SpecFP). Given this assumption, the pseudogapping facts follow directly: left-branch effects are avoided in exactly the same way that they are in any other ellipsis construction. Since a purely semantic approach to ellipsis denies the existence of syntactic structure within the ellipsis site, this explanation is unavailable, and the pseudogapping facts remain a mystery.

Our analysis of attributive comparative deletion therefore gives both substance and crucial empirical grounding to two ideas that have considerable theoretical appeal, but have lacked clear motivation: that some island effects should be located at PF, and that ellipsis is deletion of syntactic structure.

REFERENCES

- Abney, Steven: 1987, *The English Noun Phrase in its Sentential Aspect*, unpublished Ph.D. dissertation, MIT.
- Aissen, Judith: 1996, 'Pied-piping, Abstract Agreement, and Functional Projections in Tzotzil', *Natural Language and Linguistic Theory* **14**, 447–491.
- Baker, C. Lee: 1989, *English Syntax*, MIT Press, Cambridge.
- Bennis, Hans, Norbert Corver, and Marcel den Dikken: 1998, 'Predication in Nominal Phrases', *The Journal of Comparative Germanic Linguistics* **1**, 85–117.
- den Besten, Hans: 1978, 'On the Presence and Absence of *wh*-elements in Dutch comparatives', *Linguistic Inquiry* **9**, 641–672.
- Bolinger, Dwight: 1972, *Degree Words*, Mouton, The Hague.
- Borsley, Robert: 1981, 'Wh-movement and Unbounded Deletion in Polish Equatives', *Journal of Linguistics* **17**, 271–288.
- Bowers, John: 1993, 'The Syntax of Predication', *Linguistic Inquiry* **24**, 591–656.
- Bowers, John: 1987, 'Extended X-bar Theory, the ECP and the Left Branch Condition', in Megan Crowhurst (ed.), *Proceedings of the 6th West Coast Conference on Formal Linguistics*, Stanford Linguistics Association, Stanford, pp. 47–62.
- Bresnan, Joan: 1973, 'Syntax of the Comparative Clause Construction in English', *Linguistic Inquiry* **4**, 275–343.
- Bresnan, Joan: 1975, 'Comparative Deletion and Constraints on Transformations', *Linguistic Analysis* **1**, 25–74.
- Browning, Marguerite: 1987, Null Operator Constructions, unpublished Ph.D. dissertation, MIT.
- Chao, Wynn: 1988, *On Ellipsis*, Garland, New York. (Ph.D. dissertation, University of Massachusetts at Amherst, 1987.)
- Chomsky, Noam: 1965, *Aspects of the Theory of Syntax*, MIT Press, Cambridge.
- Chomsky, Noam: 1977, 'On Wh-movement', in Peter Culicover, Thomas Wasow and Adrian Akmajian (eds.), *Formal Syntax*, Academic Press, New York.
- Chomsky, Noam: 1995, *The Minimalist Program*, MIT Press, Cambridge.
- Chomsky, Noam and Howard Lasnik: 1977, 'Filters and Control', *Linguistic Inquiry* **8**, 425–504.
- Chomsky, Noam and Howard Lasnik: 1993, 'The Theory of Principles and Parameters', in Joachim Jacobs, Arnim von Stechow, Wolfgang Sternefeld, and Theo Vennemann (eds.), *Syntax: An International Handbook of Contemporary Research*, Walter de Gruyter, Berlin.
- Chung, Sandra: 1994, 'Wh-Agreement and "Referentiality" in Chamorro', *Linguistic Inquiry* **25**, 1–44.
- Cinque, Guglielmo: 1993, 'On the Evidence for Partial N Movement in the Romance DP', unpublished manuscript, University of Venice.

- Corver, Norbert: 1990, *The Syntax of Left Branch Constructions*, unpublished Ph.D. dissertation, Tilburg University.
- Corver, Norbert: 1993, 'A Note on Subcomparatives', *Linguistic Inquiry* **24**, 773–781.
- Corver, Norbert: 1997, 'Much-Support as a Last Resort', *Linguistic Inquiry* **28**, 119–164.
- Dalrymple, Mary, Stuart Shieber, and Fernando Pereira: 1991, 'Ellipsis and Higher Order Unification', *Linguistics and Philosophy* **14**, 399–452.
- Fiengo, Robert, and Robert May: 1994, *Indices and Identity*, MIT Press, Cambridge.
- Giorgi, Alessandra and Giuseppe Longobardi: 1991, *The Syntax of Noun Phrases*, Cambridge University Press, Cambridge.
- Grimshaw, Jane: 1987, 'Subdeletion', *Linguistic Inquiry* **18**, 659–669.
- Grimshaw, Jane: 1991, 'Extended Projection', unpublished manuscript, Brandeis University.
- Grosu, Alexander: 1974, 'On the Nature of the Left Branch Condition', *Linguistic Inquiry* **5**, 308–319.
- Grosu, Alexander: 1994, *Three Studies in Locality and Case*, Routledge, London.
- Haïk, Isabelle: 1987, 'Bound VPs that Need to Be', *Linguistics and Philosophy* **10**, 503–530.
- Halle, Morris and Alec Marantz: 1993, 'Distributed Morphology', in Samuel Keyser (ed.), *The View from Building 20*, MIT Press, Cambridge.
- Hankamer, Jorge: 1973, 'Why There are Two Than's in English', in Claudia Corum, T. Cedric Smith-Stark and Ann Weiser (eds.), *Papers from the 9th Regional Meeting of the Chicago Linguistics Society*, Chicago Linguistics Society, Chicago, pp. 179–191.
- Hankamer, Jorge: 1979. *Deletion in Coordinate Structures*, Garland, New York. (Ph.D. dissertation, Yale University, 1971.)
- Hankamer, Jorge and Ivan Sag: 1976, 'Deep and Surface Anaphora', *Linguistic Inquiry* **7**, 391–426.
- Hardt, Daniel: 1993, *Verb Phrase Ellipsis: Form, Meaning, and Processing*, unpublished Ph.D. dissertation, University of Pennsylvania.
- Hazout, Ilan: 1995, 'Comparative Ellipsis and Logical Form', *Natural Language and Linguistic Theory* **13**, 1–37.
- Heim, Irene: 1985, 'Notes on Comparatives and Related Matters', unpublished manuscript, University of Texas, Austin.
- Hendrick, Randall: 1990, 'Operator Movement in NP', in Aaron Halpern (ed.), *Proceedings of the 9th West Coast Conference on Formal Linguistics*, CSLI Publications, Stanford, pp. 249–261.
- Hendriks, Petra and Helen de Hoop: 1998, 'On the Interpretation of Semantic Relations in the Absence of Syntactic Structure', *University of Groningen Cognitive Science and Engineering Prepublications* 1998–3.
- Izvorski, Roumyana: 1995, 'A Solution to the Subcomparative Paradox', in José Camacho, Lina Choueiri and Maki Watanabe (eds.), *Proceedings of the 14th West Coast Conference on Formal Linguistics*, CSLI Publications, Stanford, pp. 203–219.
- Jacobson, Pauline: 1992, 'ACD in a Variable Free Semantics', in Chris Barker and David Dowty (eds.), *Proceedings from the 2nd Conference on Semantics and Linguistic Theory*, Ohio State University, Columbus, pp. 191–213.
- Jayaseelan, K. A: 1990, 'Incomplete VP Deletion and Gapping', *Linguistic Analysis* **20**, 64–81.
- Johnson, Kyle: 1997, 'When Verb Phrases Go Missing', unpublished manuscript, University of Massachusetts, Amherst.
- Kayne, Richard: 1994, *The Antisymmetry of Syntax*, MIT Press, Cambridge.

- Kennedy, Christopher: 1999a, *Projecting the Adjective: The Syntax and Semantics of Gradability and Comparison*, Garland, New York. (Ph.D. dissertation, University of California, Santa Cruz, 1997.)
- Kennedy, Christopher: 1999b, 'Local Dependencies in Comparative Deletion', in Kimary Shahin, Susan Blake and Eun-Sook Kim (eds.), *Proceedings of WCCFL 17*, CSLI Publications, Stanford, pp. 375–389.
- Kennedy, Christopher: to appear, 'Comparative (Sub-)Deletion: Evidence for Ranked, Violable Constraints in Syntax', in *Proceedings of NELS 30*, GSLA Publications, Amherst.
- Kennedy, Christopher and Jason Merchant: 1997, 'Attributive Comparatives and Bound Ellipsis', Linguistics Research Center report LRC-97-03, University of California, Santa Cruz.
- Kennedy, Christopher and Jason Merchant: 1999, 'Attributive Comparatives and the Syntax of Ellipsis', in Francis Corblin, Carmen Dobrovie-Sorin and Jean-Marie Marandin (eds.), *Empirical Issues in Formal Syntax and Semantics 2: Selected Papers from the Colloque de Syntaxe et Sémantique à Paris (CSSP 1997)*, Thesus, The Hague, pp. 233–253.
- Kester, Ellen-Petra: 1996, *The Nature of Adjectival Inflection*, unpublished Ph.D. dissertation, University of Utrecht.
- King, Harold: 1970, 'On Blocking the Rules for Contraction in English', *Linguistic Inquiry* 1, 134–136.
- Klein, Ewan: 1980, 'A Semantics for Positive and Comparative Adjectives', *Linguistics and Philosophy* 4, 1–45.
- Klein, Ewan: 1991, 'Comparatives', in Arnim von Stechow and Dieter Wunderlich (eds.), *Semantik: Ein internationales Handbuch der zeitgenössischen Forschung*, Walter de Gruyter, Berlin.
- Kuno, Susumu: 1981, 'The Syntax of Comparative Clauses', in R. Hendrick, C. Masek and M. Miller (eds.), *Papers from the 17th Regional Meeting of the Chicago Linguistics Society*, Chicago Linguistics Society, Chicago, pp. 136–155.
- Larson, Richard: 1988, 'Scope and Comparatives', *Linguistics and Philosophy* 11, 1–26.
- Lasnik, Howard: 1995, 'A Note on Pseudogapping', *MIT Working Papers in Linguistics* 27, 143–163.
- Lees, Robert: 1961, 'Grammatical Analysis of the English Comparative Construction', *Word* 17, 171–185.
- Lerner, Jean-Yves and Manfred Pinkal: 1995, 'Comparative Ellipsis and Variable Binding', in Mandy Simons and Teresa Galloway (eds.), *Proceedings from Semantics and Linguistic Theory V*, Cornell Linguistics Club Publications, Ithaca, pp. 222–236.
- Levin, Nancy: 1986, *Main-verb Ellipsis in Spoken English*, Garland, New York. (Ph.D. dissertation, Ohio State University, 1979.)
- Lobeck, Anne: 1995, *Ellipsis: Functional Heads, Licensing, and Identification*, Oxford University Press, Oxford.
- Merchant, Jason: 1996, 'Object Scrambling and Quantifier Float in German', in Kiyomi Kusumoto (ed.), *Proceedings of NELS 26*, GSLA Publications, Amherst, pp. 179–193.
- Merchant, Jason: 1999, *The Syntax of Silence: Sluicing, Islands, and Identity in Ellipsis*, unpublished Ph.D. dissertation, University of California, Santa Cruz.
- Miller, Philip: 1992, *Clitics and Constituent in Phrase Structure Grammar*, Garland, New York. (Ph.D. dissertation, University of Utrecht, 1991).
- Moltmann, Friederike: 1992, *Coordination and Comparatives*, unpublished Ph.D. dissertation, MIT.

- Perlmutter, David: 1971, *Deep and Surface Structure Constraints in Syntax*, Holt, Rinehart, and Winston, New York.
- Pesetsky, David: 1982, *Paths and Categories*, unpublished Ph.D dissertation, MIT.
- Pesetsky, David: 1998a, 'Phrasal Movement and Its Kin', unpublished manuscript, MIT.
- Pesetsky, David: 1998b, 'Some Optimality Principles of Sentence Pronunciation', in Pilar Barbosa, Danny Fox, Martha McGinnis, Paul Hagstrom and David Pesetsky (eds.), *Is the Best Good Enough*, MIT Press, Cambridge, pp. 337–383.
- Pilch, Herbert: 1965, 'Comparative constructions in English', *Language* **41**, 37–58.
- Pinkham, Jessie: 1985, *The Formation of Comparative Clauses in French and English*, Garland, New York. (Ph.D. dissertation, Harvard University, 1982.)
- Potsdam, Eric: 1997, 'NegP and Subjunctive Complements in English', *Linguistic Inquiry* **28**, 533–541.
- Potsdam, Eric: 1998, *Syntactic Issues in the English Imperative*, Garland, New York. (1996 Ph.D. dissertation, University of California, Santa Cruz.)
- Reinhart, Tanya: 1991, 'Elliptic Conjunctions – Non-Quantificational LF', in Asa Kasher (ed.), *The Chomskyan Turn*, Blackwell, Cambridge.
- Rooth, Mats: 1992, 'Ellipsis Redundancy and Reduction Redundancy', in *Proceedings of Stuttgart Ellipsis Workshop*, SFB 340 and IBM.
- Ross, John R: 1967, *Constraints on Variables in Syntax*, unpublished Ph.D. dissertation, Massachusetts Institute of Technology.
- Rudin, Catherine: 1984a, 'Comparing Comparatives', in Joseph Drogo, Veena Mishra and David Tester (eds.), *Papers for the 20th Regional Meeting of the Chicago Linguistic Society*, Linguistic Society, Chicago, pp. 334–343.
- Rudin, Catherine: 1984b, 'Comparatives and Equatives in Bulgarian and the Balkan Languages', in Kot Shangriladze and Erica Townsend (eds.), *Papers for the V Congress of Southeast European Studies*, Slavica, Columbus, pp. 328–337.
- Rullmann, Hotze: 1995, *Maximality in the semantics of Wh-constructions*, unpublished Ph.D. dissertation, University of Massachusetts at Amherst.
- Sag, Ivan: 1976, *Deletion and Logical Form*, unpublished Ph.D. dissertation, MIT.
- Shlonsky, Ur: 1991, 'Quantifiers as Functional Heads: A Study of Quantifier Float in Hebrew', *Lingua* **84**, 159–180.
- Sławski, Franciszek: 1962, *Gramatyka języka bułgarskiego* (2nd edition), Państwowe wydawnictwo naukowe, Warsaw.
- Stassen, Leon: 1985, *Comparatives and Universal Grammar*, Blackwell, New York.
- Svenonius, Peter: 1992, 'The Structural Location of the Attributive Adjective', in Erin Duncan, Donka Farkas, and Philip Spaelti (eds.), *Proceedings of the 11th West Coast Conference on Formal Linguistics*, CSLI Publications, Stanford.
- von Stechow, Arnim: 1984, 'Comparing Semantic Theories of Comparison', *Journal of Semantics* **3**, 1–77.
- Takami, Ken-ichi: 1992, *Preposition Stranding: From Syntactic to Functional Analyses*, Mouton de Gruyter, Berlin.
- Tancredi, Chris: 1992, *Deletion, Deaccenting, and Presupposition*, unpublished Ph.D. dissertation, MIT.
- Triantaphyllidis, Manolis: 1996, *Neoelliniki grammatiki (tis Dimotikis)* [Modern Greek grammar (of Demotic)], University of Thessaloniki, Thessaloniki. (Reprint of the 1941 edition.)
- Wasow, Thomas: 1972, *Anaphoric Relations in English*, unpublished Ph.D. dissertation, MIT.

- Webelhuth, Gert: 1992, *Principles and Parameters of Syntactic Saturation*, Oxford University Press.
- Wilder, Chris: 1995, 'On Some Properties of Ellipsis in Coordination', *Geneva Generative Papers* 2, 23–61.
- Williams, Edwin: 1977, 'Discourse and Logical Form', *Linguistic Inquiry* 8, 101–139.
- Woisetschlaeger, Erich: 1981, 'A Note on the Autonomy of Syntax', *The Journal of Linguistic Research* 1, 55–70.

Received 1 October 1998

Revised 12 May 1999

Department of Linguistics
Northwestern University
2016 Sheridan Road
Evanston, IL 60208-4090
kennedy@nwu.edu
merchant@ling.nwu.edu